

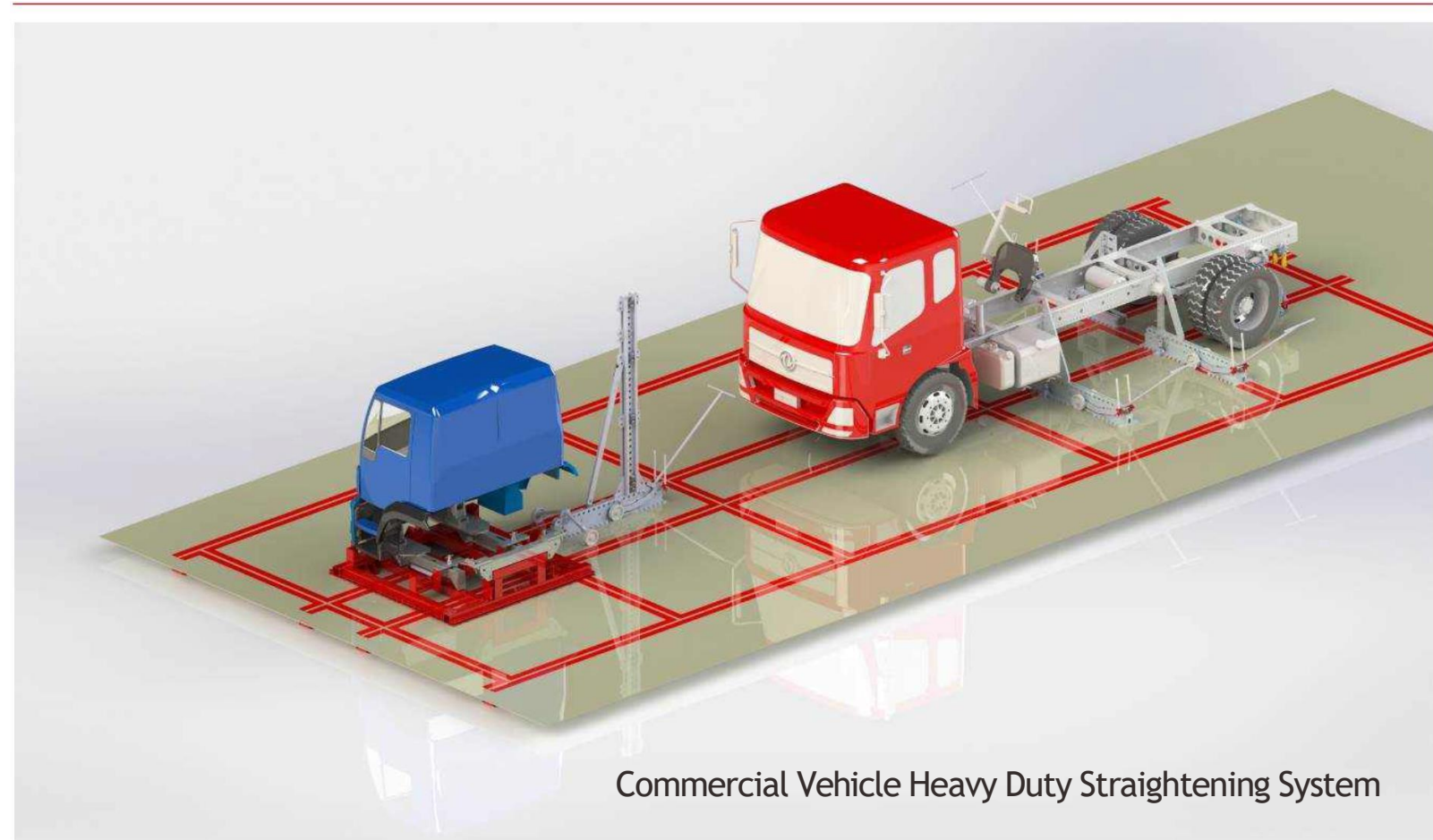

DOOCAR AUTO ENGINEERING  
 (SHANGHAI) CO.,LTD  
 NO.58 Xinyuan Road,Anting, Jiading  
 District, Shanghai  
 TEL +86-18863316058  
 FAX +86-21-39197499  
 ZIP 201805  
 E-mail info@doocarliner.com  
 www.doocarliner.com



我的工作好伙伴  
**My reliable partner**  
 мой рабочий партнёр



Cab Repair system - Precision, Professional and efficiency

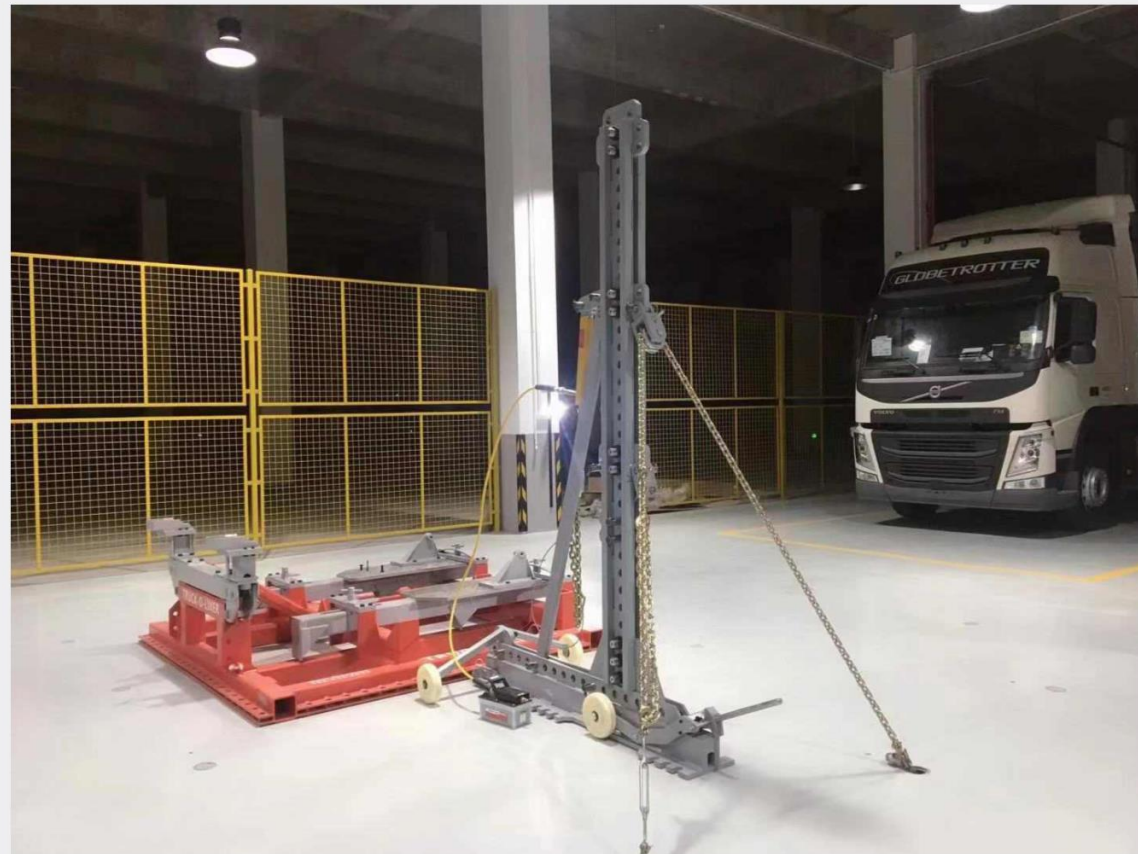

Part Two Cab Repair System



The cab BENCH system is composed of straightening bench, tooling fixture, pull tower, stretching fixture + hydraulic stretching assembly. The damaged cab is fixed by straightening tooling fixtures, and the straightening workbench X, Y, Z three-dimensional hydraulic power is used, and the base of the damaged cab can be restored to the straightening position by stretching the hand opening. straightening of pulling walls and straightening of stretching fixtures, straightening of hydraulic stretching devices, can effectively repair the cab column and ceiling.



A. CAB BENCH DO201

B. Cab Bench Basic Adapter Kit

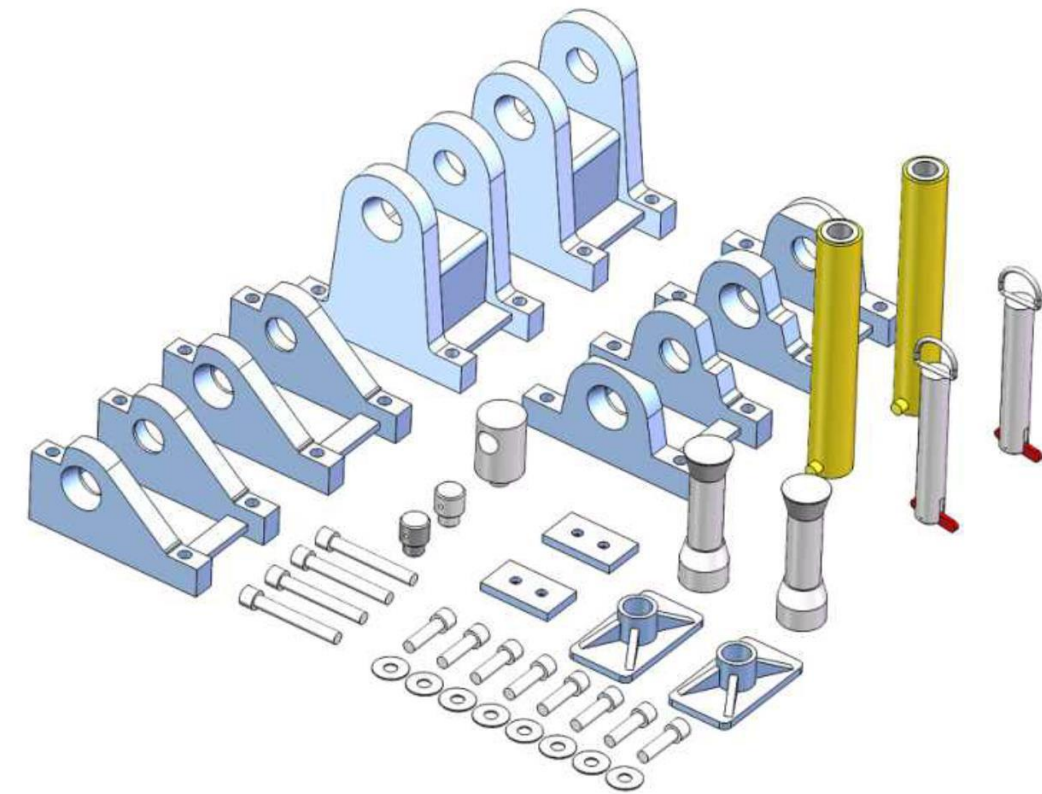
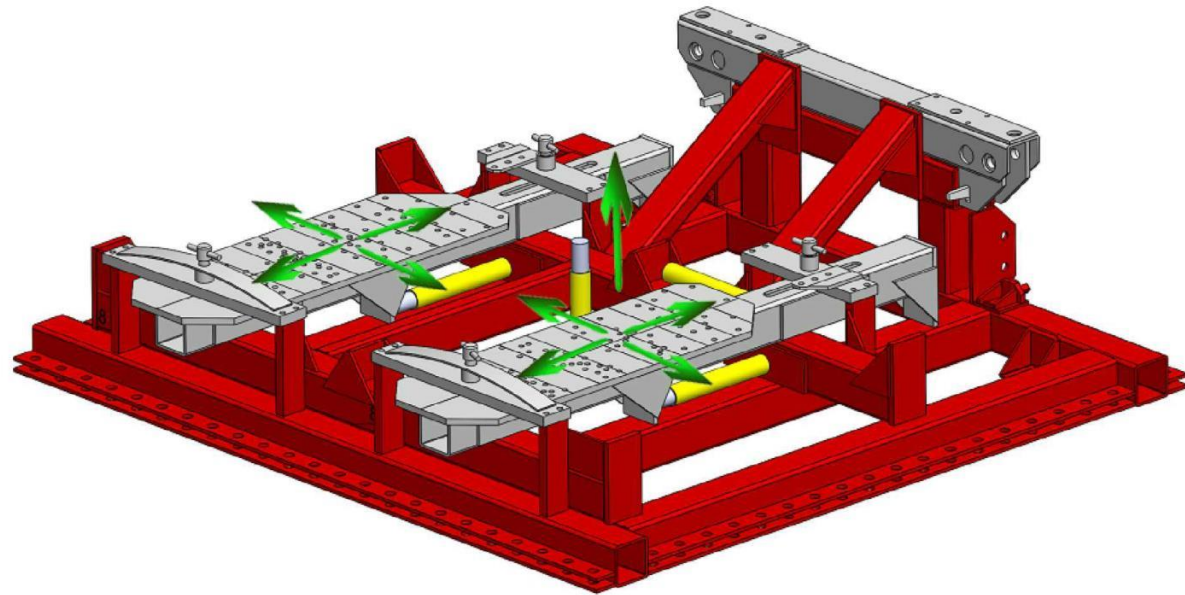

The cab straightening work platform 00201 is a solid, strong and stable work platform that can work efficiently and simplify cab maintenance operations. The official is composed of a sturdy base and a fixing kit. The base can be fixed on the I-beam track of the workshop or on the ground with the help of expansion bolts. The fixing kit is movable, which is conducive to the installation and fixation of the cab. Even the severely damaged cab is easy to fix.

According to the actual plumes of different models, we designed a special fixture to accurately and firmly fix the vehicle on the straightening work platform. Convenient for quick straightening and repair of the cab. Ducarluen already has special cab fixtures for Volvo, Scania, Daimler-Benz, MAN, Hino, FAW Jiefang, Dongfeng Commercial, China National Heavy Duty Truck, Foton Auman, and Shaanxi Heavy Truck.