

BVE-6550B X-ray Baggage Scanner



Feature Highlights

- **Safety:** World leading safety protection technology, complying all international standards for health and safety of operators and the public.
- **C-AD:** Automatically detection and alarm of a wide range of explosives, narcotics in real time during the scanning process by clearly highlighting potential threats on the X-ray image.
- **C-TIP:** Threat Image Projection function with strong image library, providing a powerful solution for operator performance monitoring and training.
- Exclusive **CETC Professional Material Discrimination Function:** with 8 selectable imaging background colors for users.
- **Customized Service** provided: meeting various end users' requirements for special software and hardware expectations.
- **High quality image** with wire resolution of 40 AWG and high steel penetration.

The BVE-6550B is an advanced x-ray system for screening regular baggage, easy to operate, specially designed to meet the needs and applications of airports, customs, prisons, courts, shopping malls, hotels, parcel services, government offices, factories or wherever high security and total screening of a large variety of dimensions required.

The BVE-6550B is a compact x-ray security inspection system with tunnel size of 656 mm width by 502 mm height. It permits the inspection of the small parcels and packages without any loss of X-ray image quality.

Operator training courses offered by CETC have an excellent reputation all over the world and they are carried out individually for each customer.

BVE-6550B offers all the advantages of CETC technology, including high-quality imaging, the industry's most user-friendly operator interface and networking capabilities. The imaging is consistently fast, accurate and efficient screening and detection of weapons, narcotics, explosives and other threats, contrabands.

General Specifications

Tunnel Size	656 (W) x 502 (H) [mm]
Conveyor Height	Approx. 662 mm
Conveyor Speed	0.2 m/s Option: 0.2m/s to 0.4 m/s (adjustable with frequency converter)
Max. Conveyor Load	160 kg
Resolution (wire recognition)	40 AWG (Typical)
Penetration (steel)	38 mm (Typical); 34 mm (Standard)
X-ray Leakage	1 μ Sv/h (5 cm from outer housing)
Duty Cycle	100 %
Film Safety	Guaranteed for ISO1600(33 DIN)

X-ray Generator Anode

Voltage • Cooling	160 kV (adjustable) • hermetically sealed oil bath
Beam directions	From bottom to top

Image Generating System

Monitor	21.5" Flat Panel LED Monitor
X-ray Converter	L-shaped multi-energy high-sensitivity detector line
Grey Level	65536
Image Presentation	B/W, color
Digital Video Memory	1920 x 1080 / 24 bit
Image Evaluation Functions	C-AD, C-TIP, O2, OS, Alarm Function, Review, Fault Self-diagnosis and Maintenance Functions, Image Navigation, System Working Timing, User Management, Emergency Stop, Working Status Display, Zoom up to 64 times, Date & Time Display, High Density Alarm, Image Magnification Display, Luggage Counting, Network Interface, One-key Shutdown, Self-check Power-on, Save and Retrieval, Ultra-thin Scanning, System on& X-Ray Emission Timing, Bi-directional scanning, Image Identification Training, Energy-saving, Free Programmable Keys.

Additional Features

Functions and Options	Printer, UPS, Entry& exit plates, Video monitoring system, Power stabilizer, LED notification bar, Speaker, Voice recorder, Bar-code, etc.
-----------------------	--

Installation Data

Noise Level	≤ 60 dB(A)
Operating / Storage Temperature	0° C – 45° C / -20° C – 60° C
Humidity	0% – 90% (non-condensing)
Power Supply	Standard: 220 VAC (+/–10%) • 50 Hz (+/- 3 Hz)
Power Consumption	Approx. 0.85 KVA
Dimension • Weight	2210 (L) x 900 (W) x 1374 (H) [mm] • approx. 570 kg
Mechanical Construction	Steel construction with steel panels, mounted on roller castors, easy to move.

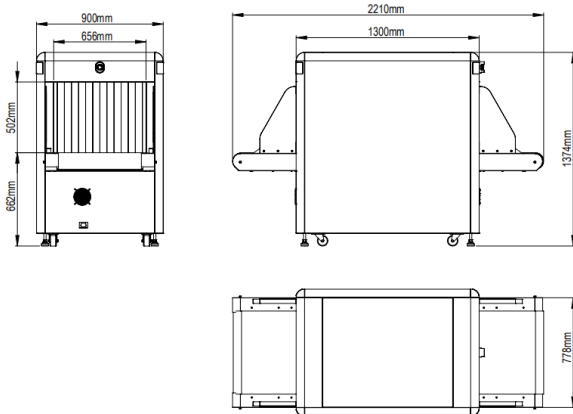

According to the national standard of the People's Republic of China GB15208.1-2018 and the international standards for radiation safety. The copyright belongs to Beijing Vacuum Electronic Technology Co., Ltd.

With continual R&D of our products, CETC reserves the right to amend specifications without prior notice. Product pictures are for general reference.



For product information, sales or service, please visit www.vetec.com.cn
Beijing Vacuum Electronic Technology Co., Ltd.

Email: security@vetec.com.cn
Tel.: +86-21-50591399

Beijing Headquarter: No.13 Jiu Xianqiao Rd., Chaoyang District, Beijing, China 100015

Shanghai Office: C12, Floor 4, Building 1, Youyue Int'l, No. 298 Xiangke Rd., Pudong, Shanghai