

Distribution Box Production

Shenzhen Superda Machine Co., LTD

<https://www.superdamc.com>

Distribution Box Enclosure IP65 IP66 Outdoor Indoor Mounted

T. 0.8-1.5mm,

Depth 150-400mm

Height 300-1200mm



Distribution Box Production Line

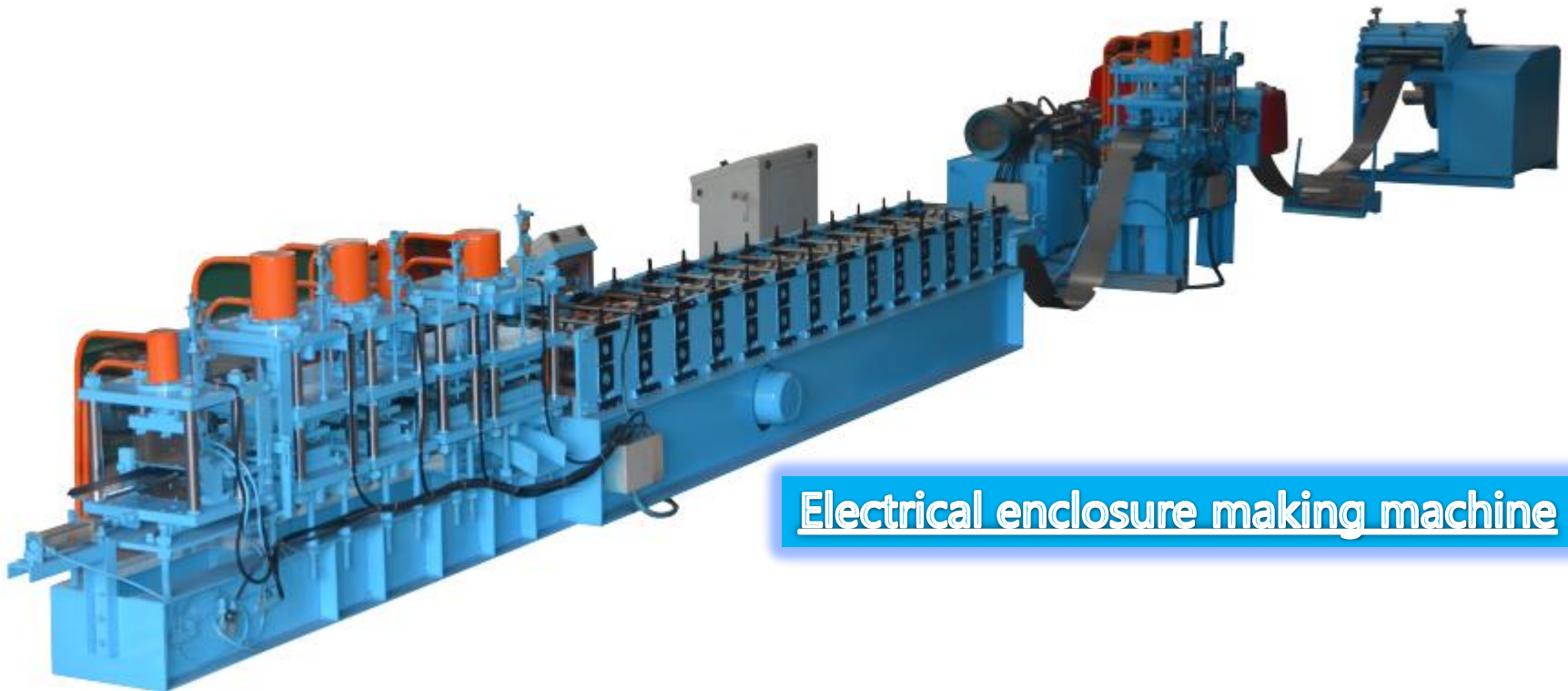

Electrical enclosure making machine



Electrical cabinet enclosure forming and bending machine production line

Cabinet Enclosure Drawing

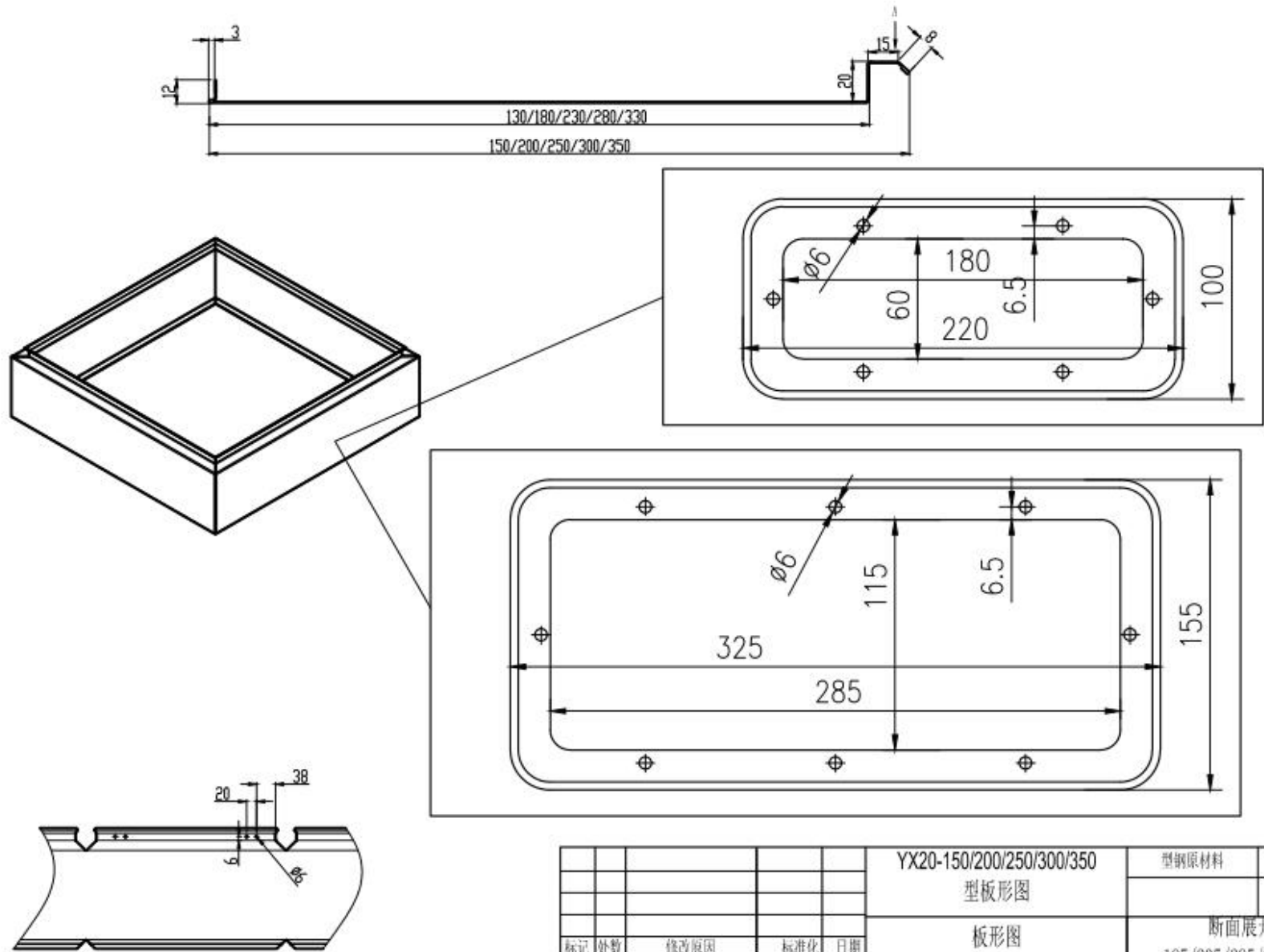

						YX20-150/200/250/300/350	型钢原材料	材料厚度
						型板形图		0.8-1.2
						板形图	断面展开宽度	
							185/235/285/335/385mm	
标记	处数	修改原因	标准化	日期			共张	第张
设计			标准化					
制图			审定					
审核			日期	2017.6.15				

Electrical Box Production Layout

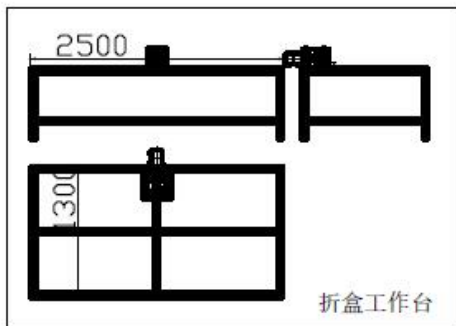
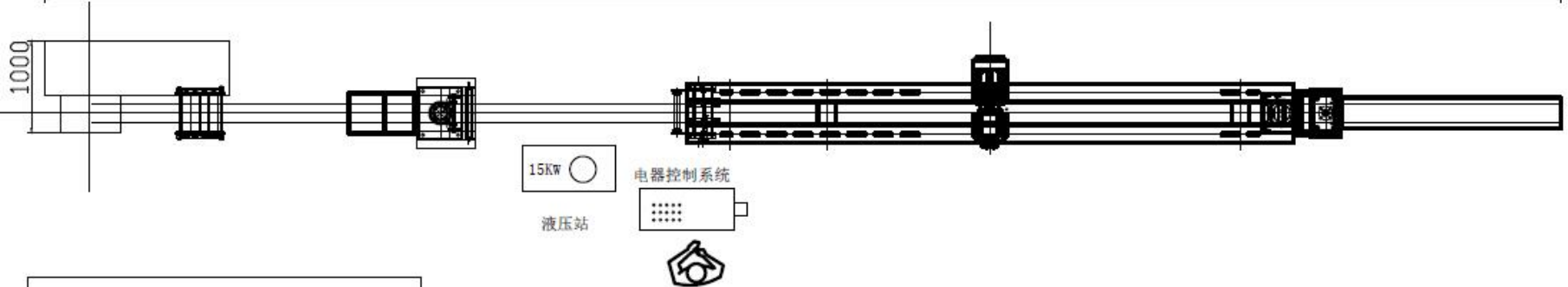
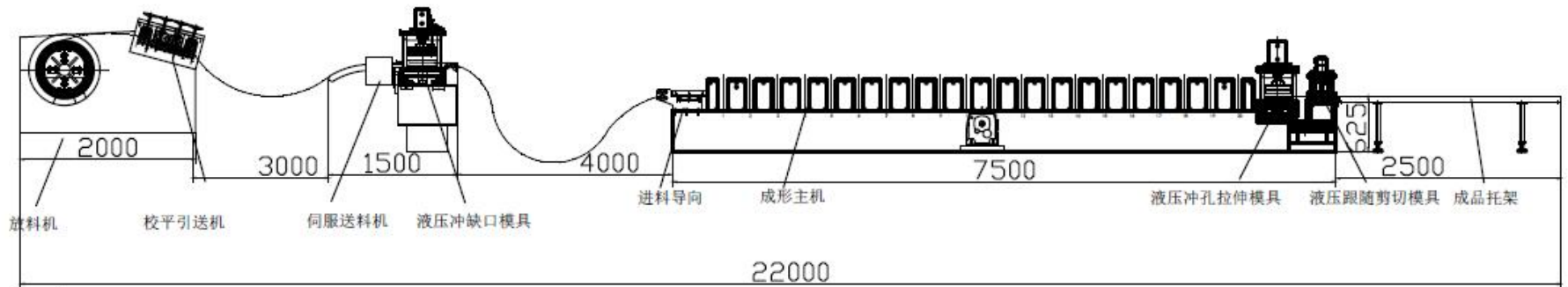

设计			YX21-200流程图		
制图					

Uncoiler and Straightener

Parameter of Uncoiler straightener

Coil weight	2T
Coil inner D.	\varnothing 450mm- \varnothing 530mm
Thickness	0.4-1.6mm
Straightener roller	7pcs



Punch box hole and box gap



Servo feeder,
Hydraulic Hole Punch
2KW servo system,
precision feeder.
Hydraulic punching
device (tool)

FORMING AND BENDING BOX



16 sets of roller station, high-quality Gr12 mold steel, HRC up to 58 ~ 60° are processed by precision CNC machine tools, precision is 6 ~ 7, surface roughness is above 0.8, no scratches on the surface.