

YX20-150/200/250/300/350 Forming machine

一、 Technical parameters

No.	ITEM	PARAMETER	REMARK
1	MATERIAL	Type	Cold-rolled strip steel, galvanized sheet
		T. (mm)	0.8-1.2mm
		Yield Strength (Mpa)	Q235
2	Forming product Width	150, 200, 250, 300, 350mm	
3	Forming speed (m/min)	2-8m	Including hole
4	Forming main power (KW)	7.5 KW	FYR
5	Hydraulic power (KW)	18.5 KW	FYR
6	Bending power (KW)	3 KW	FYR
7	Voltage	AC380V, 50Hz, 3P	

二、 process

(A) 2 in 1 Uncoiler Straightening → servo feeder → Hydraulic press breach device → Guide device → roll forming machine → hydraulic punch → shear device (including knife) → finished product rack

(B) Bending machine with tool

Layout as below:

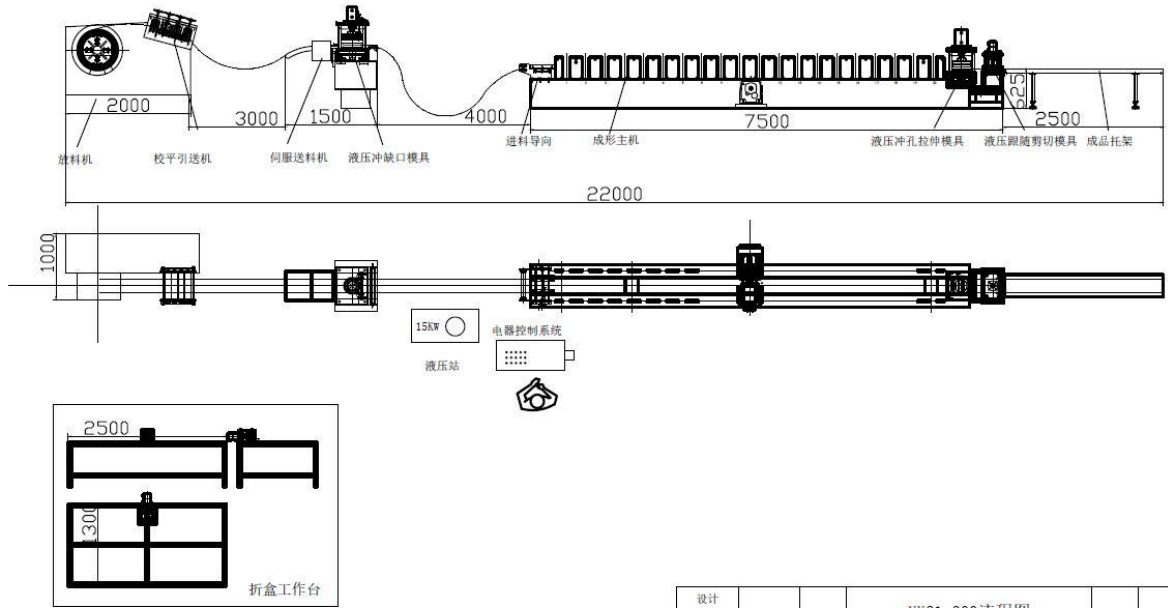

设计			YX21-200流程图		
制图					
标准化					

三、Plate drawing as below:

Section part Drawing:

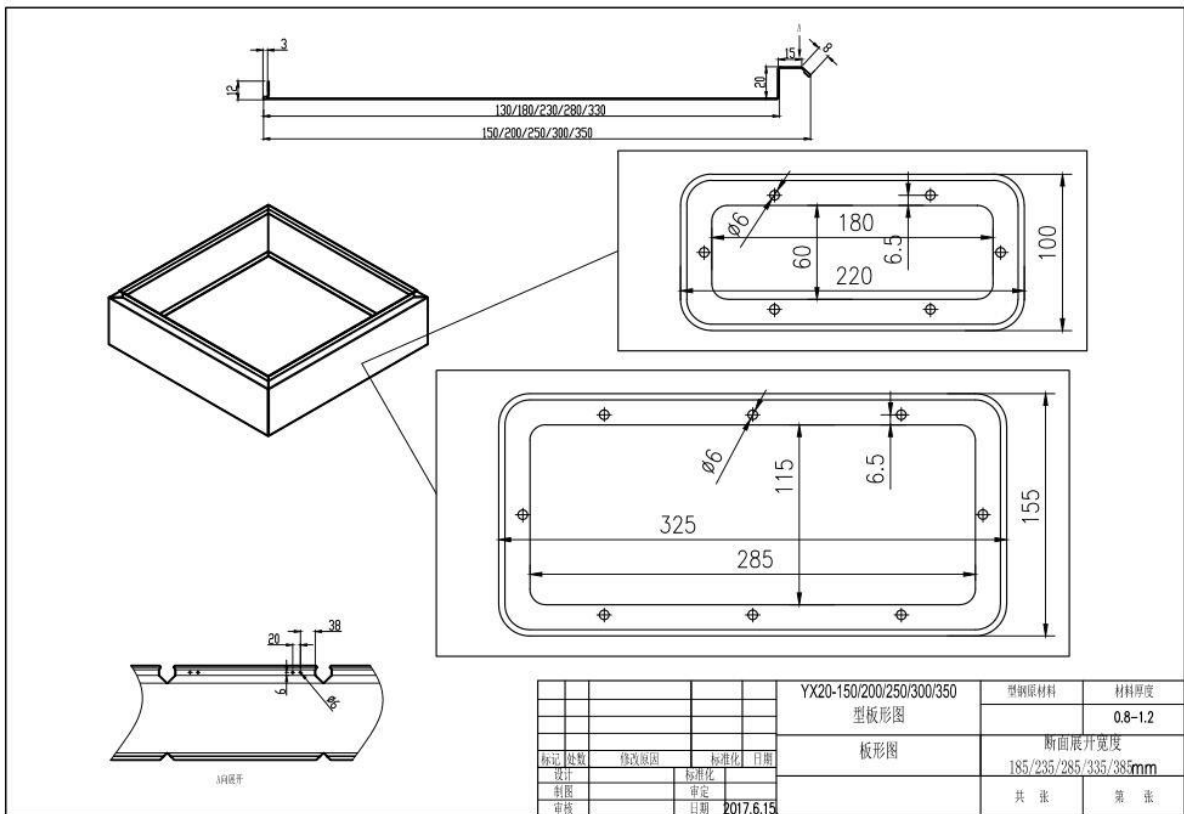

四, Machines List

一) 2 in 1 Uncoiler straightener

1、 Type: Manual Expansion

2、 Parameter

1) Passive discharge

2) Coil weight: < 2T

3)Coil inner D. : ϕ 450mm- ϕ 530mm

4) Max. Width. 400mm

5) Thickness .0.4-1.6mm

6) Straightener roller :7 pcs

8) Power. 1.5kw



Photo just for reference

二) , Servo Feeder

3.1 Max. feeding width:400mm

3.2 Feeding thickness: 0.4-1.6mm

3.3 Motor , 1.3 K W(Yaskawa)

Photo just for reference



三), Hydraulic hole punching system

3.1 Function: Hydraulic punch breach (Mould 1 set)

3.2 Structure: set the length, automatic length measurement, automatic positioning reaches the set distance stop action , hydraulic cylinder driven punching die, stamping automatic shutdown.

3.3 Hydraulic system working pressure: 16MPa

3.4 Hydraulic station: 18.5KW (Hydraulic punch hole/shear use same station)

四) Guide device

五) Main Forming machines (for panel width 150,200,250,300, 350mm)

6.1 Forming Roller: 20 stations, and add Rub-roll, To make sure the surface profile no scratches.

6.2 Side Panel: T.18mm ,A3 steel Heavy duty 。

6.3 Rolling speeding: 2-8 m/min。

6.4 Roller material: GCr15, overall quenching, hardness HRC56-62 °C.

6.5 Motor power: 7.5KW。

6.6 Main Roller : \varnothing 75mm, 45 #。

6.7 Equipment base: 45 # H type using welded steel plate.

6.8 Transmission: chain drive.

6.9 Security: across the board with emergency stop buttons, easy to handle emergencies, to ensure that equipment and operator safety. And other gear in the chain and the staff could easily lead to injury transmission section covered with protective cover, to ensure the safety of workers.

Photo just for reference

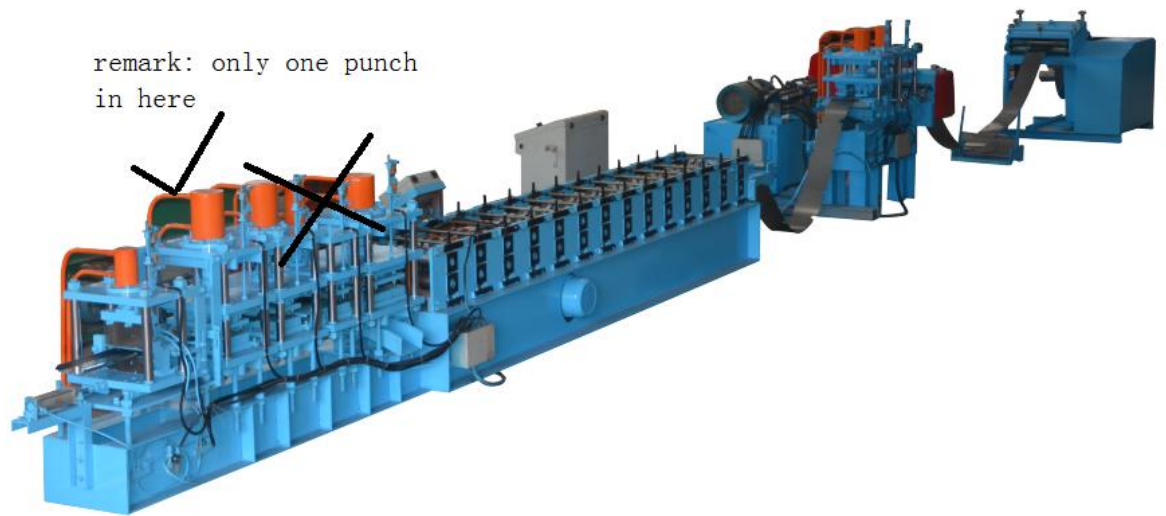

六) 、 Hydraulic **Punch Machine** /Follow shear

6.1 Hydraulic Punch machine

(With 2 mould. 285*115mm, 180*60mm)

6.2 Follow shear (Cut style): Hydraulic cut (No blanking), Machine non-stop can cut product.

Knife material: Cr12, quenching hardness of up to HRC56-58 degrees.

八) 、 Flat collect rack

九) 、 Box Bending Machine (including mould) 150/200/250/300/350
1 set , Hydraulic power :3kw

十) 、 Electrical control system

The entire line imported PLC control, LCD touch screen, man-machine interface. People interact with the PLC. Operator setting the program to run automatically (programmable control) and control process monitoring, production line operator control and modify the control parameters, and real-time monitoring the

equipment status & parameters and fault indication. Workpiece length digital setting, adjustable length can be adjustable as well. Real-time monitoring of equipment operating status and fault indication.

Operation manual / automatic two styles. With manual and automatic switching function: In the manual mode, can be stand-alone operation, easy maintenance; In automatic mode, carry out full production run, in order to start; across the board with emergency stop buttons, easy to handle emergencies, to ensure that equipment and operating personnel Safety.

** The main components of the brand:

PLC control system: **Siemens**

Inverter: Taiwan Shilin

Encoder: Omron

Touch screen: **Siemens**

Some components are Schneider brand devices.

Devices:

No.	Machine name	QTY	REMARK
1	Uncoiler straightener	1	
2	Servo Feeder	1	
3	Hydraulic machine	1	With mould
4	Guide device	1	
5	Forming machine	1	
6	Hydraulic machine	1	With mould (2 sets)
7	Follow Shear	1	Including knife

8	Collect rack	1	
9	Control system	1	
10	Box bending machine	1	With mould

Brand

No.	Name	manufacturer
1	Motor & Reducer	Domestic brands
2	The main key bearing	Domestic brands
3	Inverter	Shilin
4	PLC Systems	Siemens
5	Low-voltage electrical	Schneider
6	Encoder	Omron
7	touch screen	Siemens
8	Hydraulic system	Domestic brands