



China Light-Sky Technology Co., Ltd.

Address: 5/F, Building 2, Sanwei Industrial Park, Xixiang Town,
Bao'an District, Shenzhen City, China 518128

Tel: +86-755-29100681 Fax: +86-755-29455551 Web: www.light-sky.com

Technical Sheet

Product Name	<u>LED high bay lights</u>
Item No.	<u>CLS-HB200-UFO-MW</u>
Power	<u>200 watts</u>

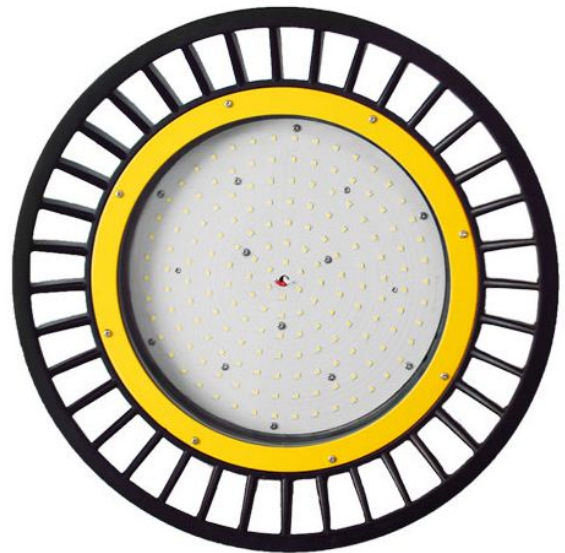

Product Dimension :
200w LED high bay lights

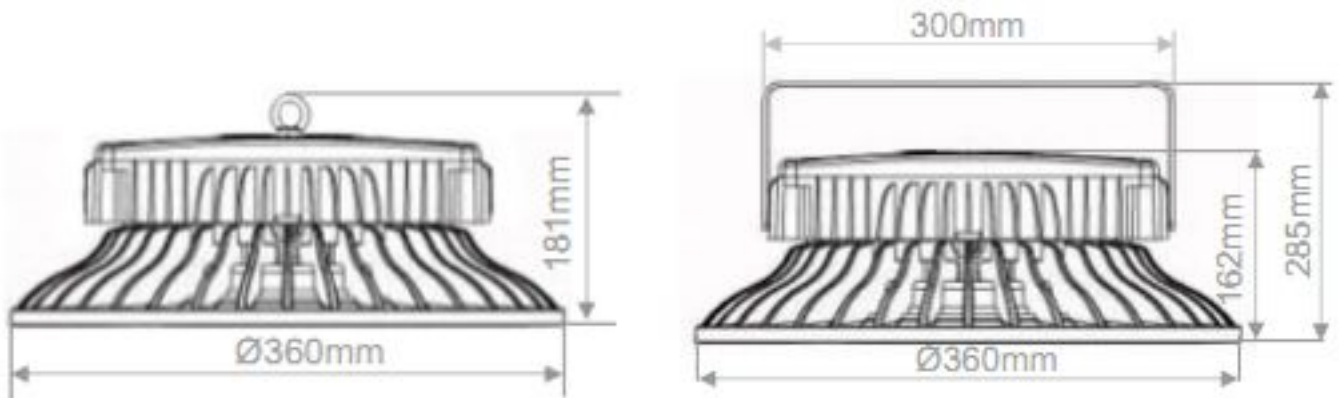

Brief Information for 200w LED high bay lights

Power: 200 watts
LEDs: Philips led
Warranty: 5 years

Output Lumens: 24000lm
IP grade: IP65
Driver: Meanwell Driver

节能减排 领航绿色照明
Leading Green Lighting



China Light-Sky Technology Co., Ltd.

Address: 5/F, Building 2, Sanwei Industrial Park, Xixiang Town,
Bao'an District, Shenzhen City, China 518128

Tel: +86-755-29100681 Fax: +86-755-29455551 Web: www.light-sky.com

200w specification parameter

Item No.	CLS-HB200-UFO-MW
Power	200w
Lumen	24000lm
Power Factor	0.98
Input Voltage	AC90-305V
CCT	4300K, 5000K
CRI	Ra>80
Luminous Efficiency	110-125lm/w
LED Chip Brand	Philips led
LED Driver Brand	Meanwell Driver Brand
Housing Color	Black & Gray
IP Grade	IP65
Beam Angle	110 & 120 degree
Material	Aluminum
Working Temperature	-25℃~+50℃
Lifespan	50000 hours
Packing CBM	450*450*260mm≈0.053m ³
Pcs/ctn	1
Gross Weight	11.50kg
Warranty	5 years



China Light-Sky Technology Co., Ltd.

Address: 5/F, Building 2, Sanwei Industrial Park, Xixiang Town,
 Bao'an District, Shenzhen City, China 518128

Tel: +86-755-29100681 Fax: +86-755-29455551 Web: www.light-sky.com

Luminous Intensity Distribution

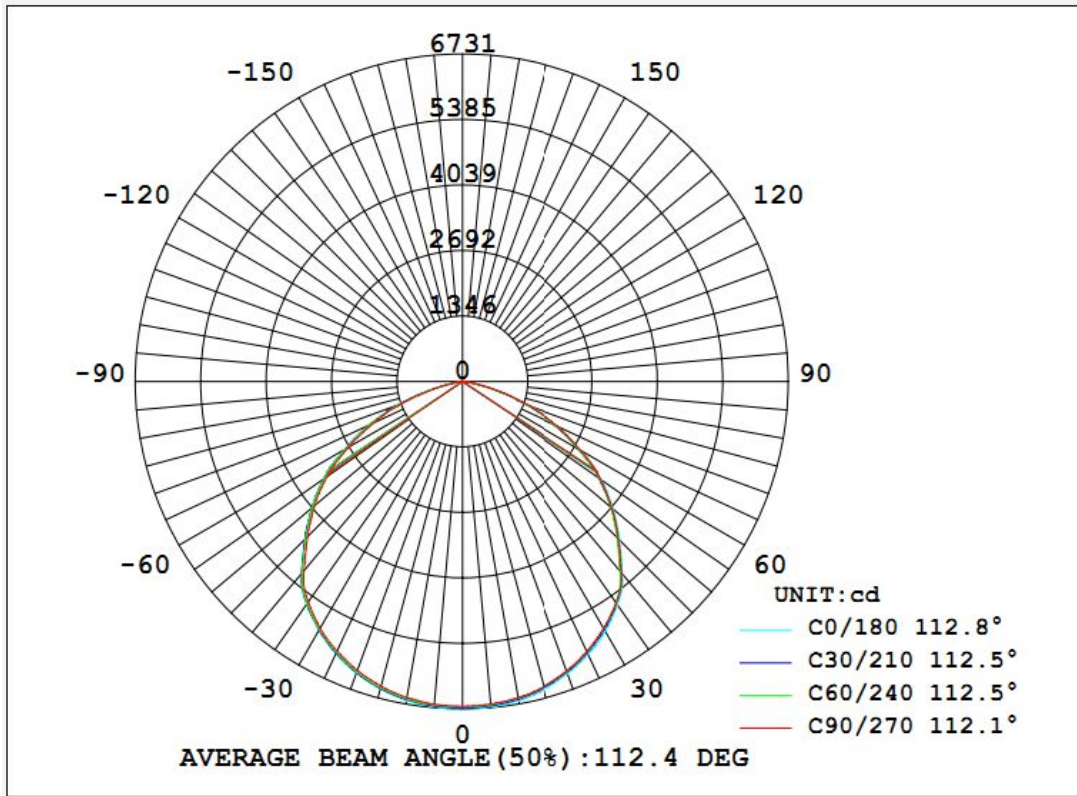

Flux Illumination Lighting

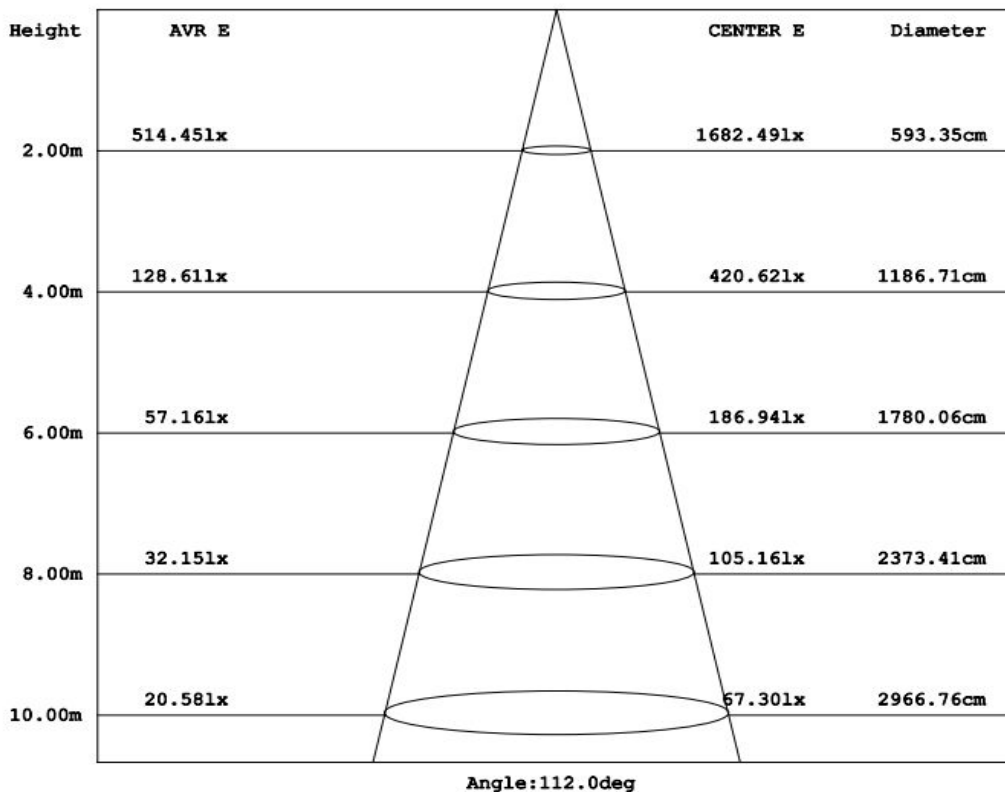



China Light-Sky Technology Co., Ltd.

Address: 5/F, Building 2, Sanwei Industrial Park, Xixiang Town,
Bao'an District, Shenzhen City, China 518128

Tel: +86-755-29100681 Fax: +86-755-29455551 Web: www.light-sky.com



With the improvement of LED technology, LED high bay lights, as the main luminaires of industrial lighting, are widely used. With better performance, it is inevitable trend to use LED replace traditional lamps.

China Light-Sky LED high bay lights, adopting high efficiency optical system, uniform and good vertical light distribution, lower glare, is the ideal solution for LED high bay lighting.

Key Features

- Unique designed UFO shape , lighter and smaller
- Nichia 3030 & Philips 3030 , Ra> 80; LM80 standard
- Meanwell led driver
- Glass cover or PC convex cover
- Wide aluminum plate design, heat dissipation fast and evenly
- Ideal mounting height: 8-10 m
- Installation: Rack mounting & Hook hanging
- Working temperature: -20°C ~ + 50°C
- IP65 protection level

Product Features

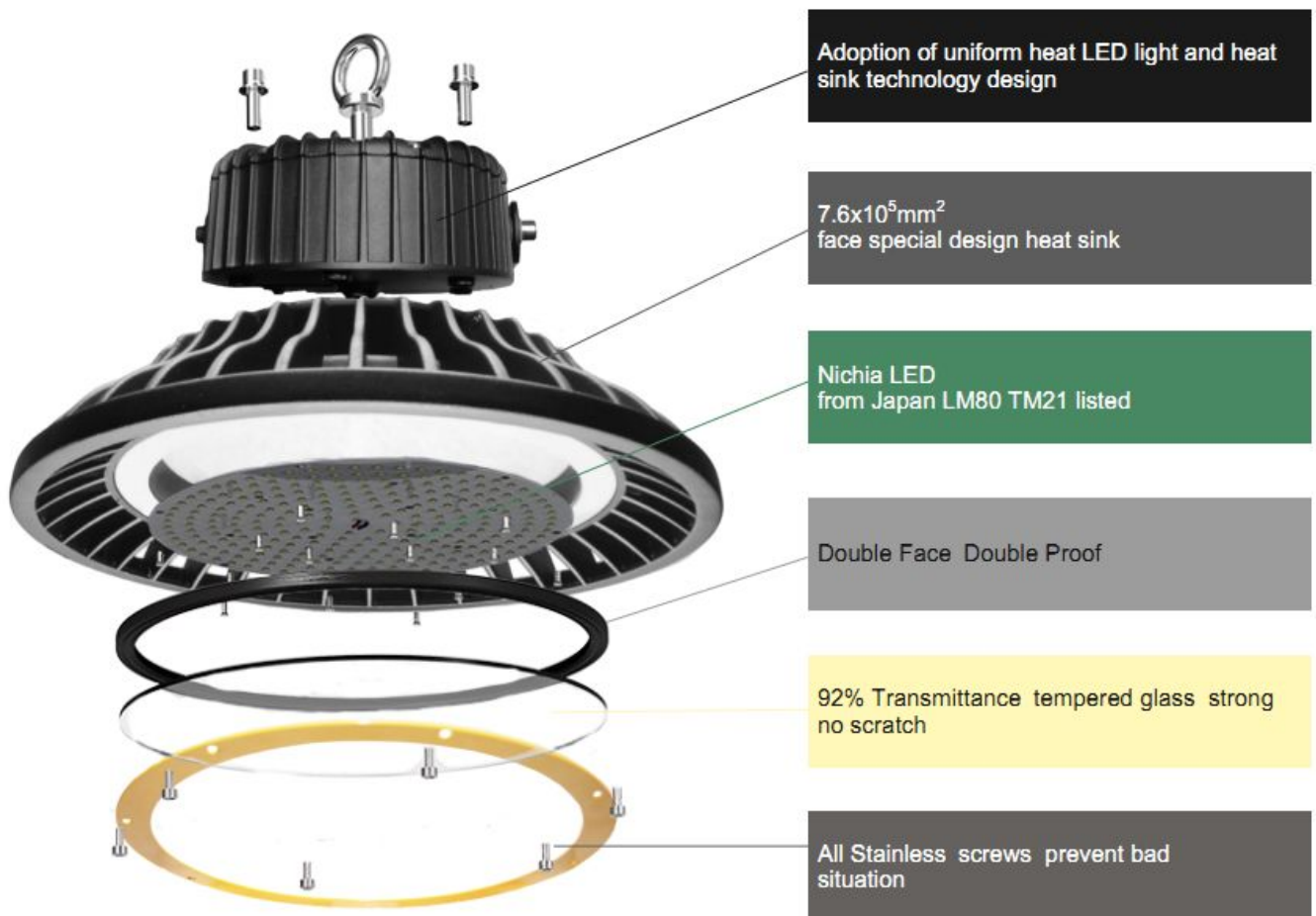

节能减排 领航绿色照明
Leading Green Lighting



China Light-Sky Technology Co., Ltd.

Address: 5/F, Building 2, Sanwei Industrial Park, Xixiang Town,
 Bao'an District, Shenzhen City, China 518128

Tel: +86-755-29100681 Fax: +86-755-29455551 Web: www.light-sky.com

Dialux Comparison Chart

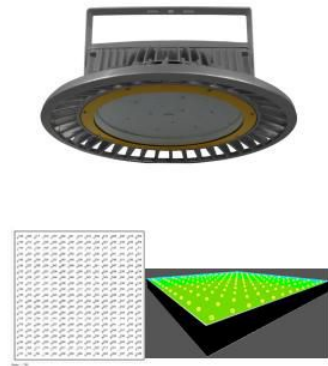

Height of room: 8.000 m, Height of working plane: 0.800 m, Wall zone: 0.000 m
 Reflection factors: Ceiling 70.0%, Walls 50.0%, Floor 20.0%, Light loss factor: 0.80

Workplane

Surface	Result	Mean (target)	Min	Max	Min/Average	Min/Max
1 工作面 1	Perpendicular Illuminance [lx]	225 (50)	91	253	0.404	0.360

No.	Quantity
1	156

DIALux
 Light output ratio: 101.60%
 Lamp luminous flux: 16394 lm
 Luminaire Luminous Flux: 16656 lm
 Power: 147.1 W
 Light yield: 113.2 lm/W

Total lamp luminous flux: 2507484 lm, Total luminaires luminous flux: 2598338 lm, Total Load: 22847.6 W, Light yield: 113.2 lm/W
 Specific connection value: 2.29 W/m² = 1.02 W/m²100 lx (Ground area: 10000.00 m²)

CLS	VS	Others
150W	Power	150W
138pcs	Lamps installation	182pcs
200	Eav Average Lux	200
0.404	U0 Light Uniformity	0.345
20786.7	P[W] Total Power Consumption	27318.2
2598336	T[lm] Total Lumen	2288468

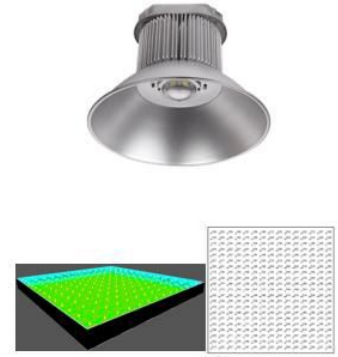

Height of room: 8.000 m, Height of working plane: 0.800 m, Wall zone: 0.000 m
 Reflection factors: Ceiling 70.0%, Walls 50.0%, Floor 20.0%, Light loss factor: 0.80

Workplane

Surface	Result	Mean (target)	Min	Max	Min/Average	Min/Max
1 工作面 1	Perpendicular Illuminance [lx]	203 (50)	70	288	0.345	0.243

No.	Quantity
1	182

DIALux
 Light output ratio: 123.38%
 Lamp luminous flux: 10191 lm
 Luminaire Luminous Flux: 12574 lm
 Power: 150.1 W
 Light yield: 83.8 lm/W

Total lamp luminous flux: 1864762 lm, Total luminaires luminous flux: 2288468 lm, Total Load: 27318.2 W, Light yield: 83.8 lm/W
 Specific connection value: 2.73 W/m² = 1.36 W/m²100 lx (Ground area: 10000.00 m²)

Replacement Table

LED High Bay Light	Metal Halide High Bay Light
150W	400W
180W	600W
200W	600W
240W	750W

Application For LED high bay lights

Warehouse; industrial production workshop; pavilion; stadium; the train station; shopping malls; gas stations and other indoor lighting



China Light-Sky Technology Co., Ltd.

Address: 5/F, Building 2, Sanwei Industrial Park, Xixiang Town,
Bao'an District, Shenzhen City, China 518128

Tel: +86-755-29100681 Fax: +86-755-29455551 Web: www.light-sky.com

Installation Type

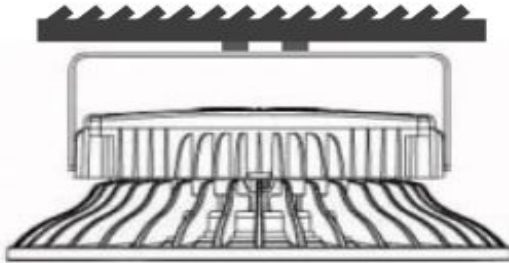

Bracket hanging

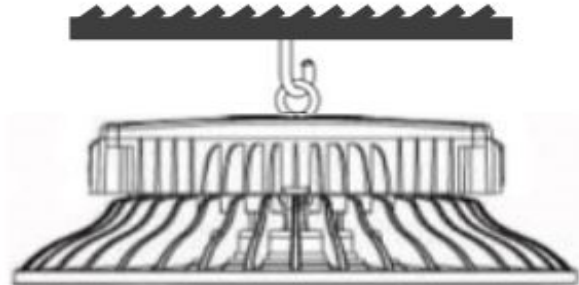

Hook hanging

Installation (Hook Hanging and Bracket Hanging)

Features:

UFO LED high bay, designed for industrial lighting. Adopting the newest LED lighting technology, longer lifespan, lower maintenance cost, higher efficiency. Unique designed optical light distribution can focus the light to the lighting area, improving the luminaire efficiency, taking the place of traditional HID lamps. The wire is made of flame retardant cable which reaching 90VO grade. Wire in blue (AC input wire), brown, (AC input wire) and lime-green(earth wire).



Notice:

1. In case of fire, explosion, electronic shock, the install, inspect and maintenance must be operated by professional people.
2. Pls make sure the power off before operation! Luminaries must be electronic grounding!
3. Pls make the voltage supplied is available for the luminaries!
4. Pls make the luminaries working under the limited working temperature!
5. In order to guarantee enough air convection, luminaries should not be installed in narrow space!

Warranty:

1. All products use constant LED driver, LED chips, 5 years warranty. (under the condition that products are rightly kept, installed, used, and maintenance. Once the products fail because of improper used or installed or break the products operation manual, we are not responsible for this situation. We will repair or replace the broken products during the warranty. We will charge extra material and labor cost if over warranty.
2. Pls read the instruction manual careful, all rights reserved.
3. All products are subject to change without notice.



China Light-Sky Technology Co., Ltd.

Address: 5/F, Building 2, Sanwei Industrial Park, Xixiang Town,
Bao'an District, Shenzhen City, China 518128

Tel: +86-755-29100681 Fax: +86-755-29455551 Web: www.light-sky.com

Maintenance manual:

1. Cut off power before maintenance
2. Clean the glass of LED street light regular to keep good light transmission.
3. Clean the dusk on the surface and heat sink regular to keep good heat dissipation.
4. Do not use water or strong corrosive liquid to clean the lamp, dry cloth is better.
5. Replace LED driver: use screwdriver to open the cover, fetch out the driver. You can see three AC wires, Match brown wire with "L", Blue with "N", Kelly or yellow with "G". The red or white wire on driver is the positive electrode, black wire is the negative electrode. Notice, pls confirm the positive and negative electrode has not met extremely instead.

Hook hanging :

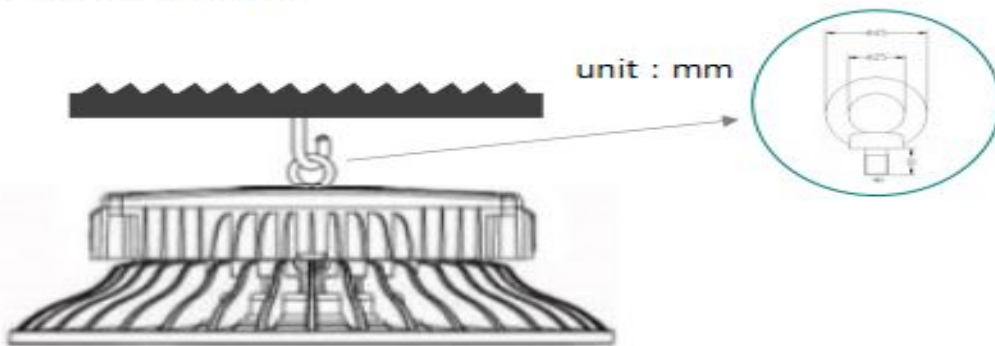

Attention:

Lamp must be vertical suspension and the supporter should can bear at least 3 times weight of the lamp. Luminaires should not be installed where it is draught, in case of shaking and unstable.

Hook installation steps:

1. Cut off power before operation.
2. Knowing the inside diameter of the luminaires then Choose suitable hook for the luminaires.
3. Fix the hook before installation and make the it can bear over 3 times weight of the lamp
4. Connect the lamp with hook and make it is safe.
5. Connect the power wire : Brown, "L", connect to LIVE; Blue, "N", connect to NEUTRAL; Lime-green, connect to EARTH/GROUND
6. Light up the luminaires!

Bracket Hanging :

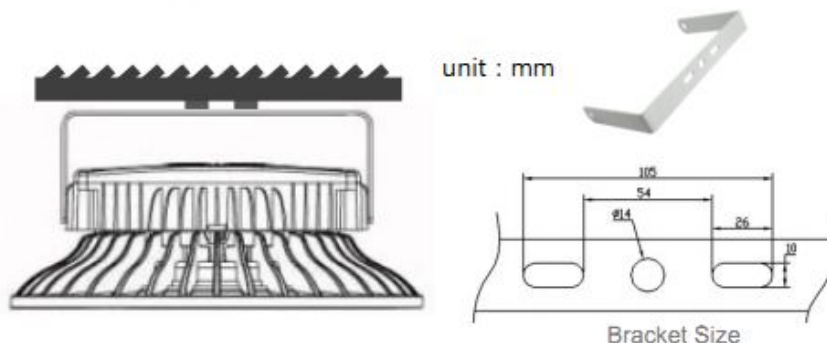



China Light-Sky Technology Co., Ltd.

Address: 5/F, Building 2, Sanwei Industrial Park, Xixiang Town,
Bao'an District, Shenzhen City, China 518128

Tel: +86-755-29100681 Fax: +86-755-29455551 Web: www.light-sky.com

Attention:

Lamp must be vertical suspension and the supporter should can bear at least 3 times weight of the lamp.

Bracket installation steps

1. Cut off power before installation.
2. Measure the hole size on the holder, choose suitable screw.
3. Fix the screw at the place where luminaires will be installed and it should can bear over 3 times the weight of the luminaires
4. Screw up the screws at both sides of holder, then connect the hold hole with screws, tighten it up.
5. Connect the power wire : Brown,“L”, connect to LIVE; Blue, “N”, connect to NEUTRAL; Lime-green, connect to EARTH/GROUND
6. Light up the luminaires !