

# Operating instruction

## Manual Coating equipment

COLO-800D



## FUNCTIONS

.The fluidized powder in the powder hopper is sucked up in the injector by the conveying air. Through the powder hose the powder air mixture reached the gun

.The powder is electrostatically charged immediately it reaches the gun nozzle. An intense field also exists between the gun nozzle and the grounded workpiece. The electrostatically charged powder sprayed onto the workpiece adheres to the latter's surface.

.This line voltage is converted in the control module to high-frequency current this current stepped up by the high-voltage transformer and the HV-cascade in the gun to 100KV and applied to the electrodes.

.The conveying air and the dosing air is to be regulated on the control module, the fluidizing air on the pneumatic unit.

.The powder is fluidized by forcing air from blow through a porous plastic plate.

.The fluidized powder gets liquid-like properties..

## → Technical Data

Power range	100-240 VAC
Frequency	50/60HZ
Input power	50W
Temperature range in use	-10 °C+50 °C
<b>Powder Gun</b>	
Gun weight: .....	500G
Input voltage .....	MAX12V
Input current .....	MAX1A
Maximum output current .....	180UA(max)
Maximum output voltage.....	0-100KV ( adjustable)
Maximum powder injection :.....	600g/min
Polarity .....	negative (-)
<b>Pneumatic technical spec</b>	
Maximum input-air pressure .....	10 bar / 145 psi
Optimum input-air pressure.....	6 bar / 87 psi
Maximum water vapor content or compressed air .....	1.3 g/m <sup>3</sup>
Maximum oil vapor content of compressed air .....	0.1 mg/m <sup>3</sup>
Maximum compressed-air consumption.....	13.2 m <sup>3</sup> /h

## Dimensions

Width	690mm
Depth	800mm
Height	1135mm
Weight	45kgs

# Connecting guide

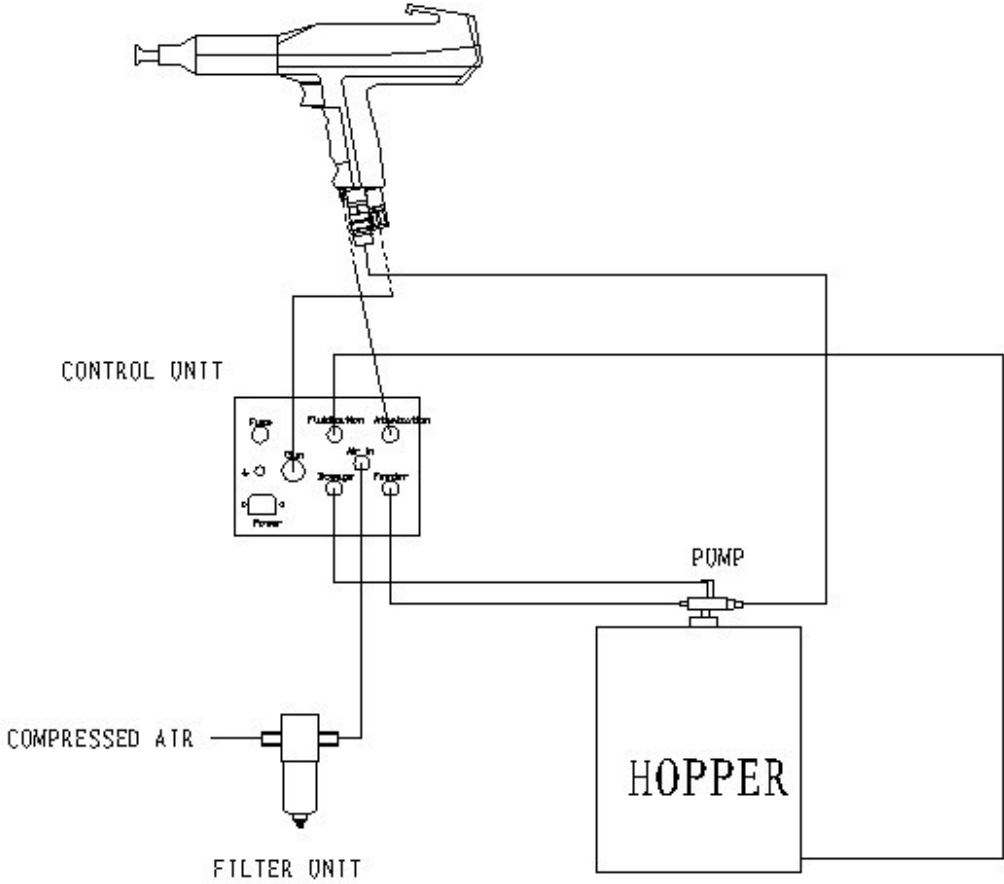

## Manual Gun

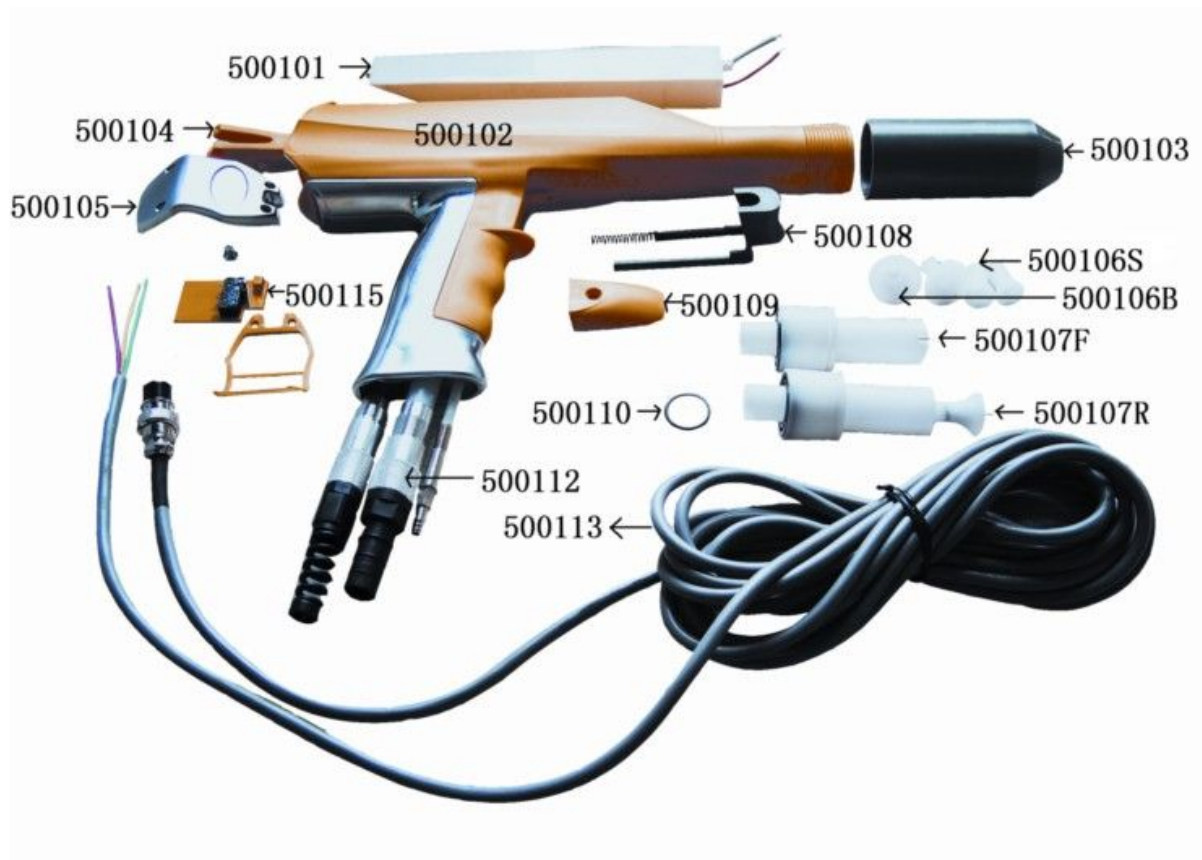

PLS supply the item number will order the spare parts for colo gun !

## Structure

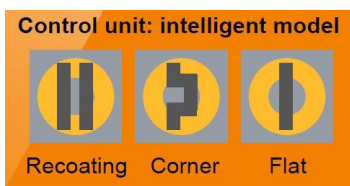

### Manual coating equipment-structure

- |                           |                                         |
|---------------------------|-----------------------------------------|
| 1 control unit            | 2 Manual powder gun                     |
| 3 injector                | 4 Mobile frame with hand rail (trolley) |
| 5 Fluidized powder hopper | 6 Powder filler flap                    |
| 7 Swivel wheel            | 8 Filter unit                           |
| 9 Gun holder              | 10 Shelf                                |
| 11 Hose holder            | 12 Hose holder                          |
| 13 Rubber wheel           |                                         |

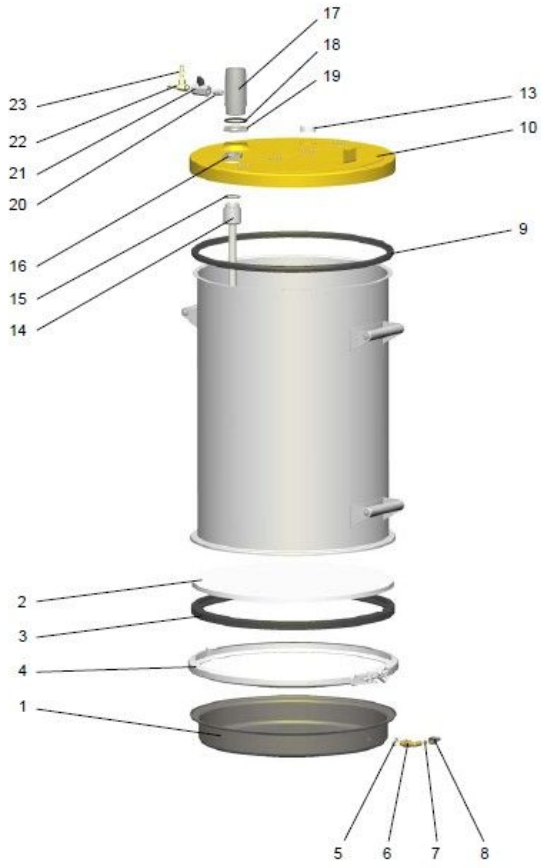

**Powder hopper**



Powder injector

## > WARNING

### --INSTALLATION

- Properly ground all equipment in the spray area to an earth ground and maintain this ground
- Remove all containers of volatiles from the spray area
- Establish and maintain a grounded area for the spray operator
- The gun of x series must be connect to x control unit

### → OPERATION

- The operator should hold the gun in his bare hand
- If gloves are worn, the palm should be out to assure skin to metal contact
- The operator should wear shoes with conductive soles e.g. leather. Rubber shoes are not conductive.
- Ground the tip of the gun before cleaning or changing nozzles.
- When the gun is not in use, it should be hung so that the nozzle is within four inches of a grounded conductor
- The operator should wear a filter-type respirator anytime he is exposed to dusty conditions
- High pressure powder may cause injury, Keep the rear switch "off" position in non-use condition

### → MAINTENANCE

- Make a periodic confirmation of grounding to earth of all equipment in the spray area.
- Exercise good housekeeping practices, do not allow dirt or powder to accumulate on the feeder / powder unit, cable or gun.
- Keep the cabinet door

## PERSONNEL

- Use soap and water to remove powder from the skin. Washing with solvents can cause reactions resulting in allergies and disorders.
- Wash hands before eating and smoking.
- Do not use compressed air to blow powder off the hands and clothing. This practice may result in damage to the ear drums or eyes.

## 2. INSTALLATION

- Connects the control units MAIN AIR to MAIN AIR(REGULATOR) output unit with air hose
- Connects the control unit DOSING AIR to INJECTOR with air hose
- Connects the FLUIDIZING AIR (REGULATOR) output unit to HOPPER with air hose
- Connects the control unit AUXILIARY AIR to GUN with air hose
- Connects the POWDER HOSE to INJECTOR
- Connects the GUN CABLE to CONTROL UNIT with air hose
- Connects ground connection cable from ground nut to the booth and trolley
- Connect main powder cable

## **3. OPERATION**

### **→PREPARATION FOR TEST OPERATION**

#### **1. Adjustment for for voltage selection**

All the shipped equipments are fixed at REQUEST

#### **2. Connection of air supply**

.Compressed air must not contain any oil or moisture

.It should be noticed that the oil and moisture container in the compressed air must be filtered out.

.The fluidified air must be locked in until all connections are completed.

#### **3. Connection outlet hose**

.Connect the hose by pressing it into the hoppers outlet –hose coupling hole.

.Place the opposite end of the hose within booth.

Caution:Atmospheric pressure should be present in the hopper during operation of the equipment

#### **4. Connect ground line**

The ground line should be connected to booth or conveyor with a clip

#### **5. Safety regulations:**

- 1) Operator should always take precaution to get grounded to the powder electroatic machine s GUN handle by marking hole in his gloves , He should also make it a rule to put on a pair of grounded shoes.
- 2) The floor of workplace should be conducted
- 3) All conduction material with 5 meters around powder booth are completely grounded
- 4) Fact the GUN to dircetion of BOOTH and not to the human body
- 5) In case of powder such as spaying paint ,dust density of 10g/ m<sup>3</sup>  
Or more could cause explosion ,and the internal booth should be maintained in good and clean condition .

## **CHECK FUNCTION OPERATION**

### **1. Functions**

- 1) cuts off the powder supply from pressure-decrease valve.
- 2) Lowers the control box high –voltage adjustment handle down to bottom –lef position .
- 3) See what happens when the high-voltage adjustment handle is turned from to right to slowly increase the voltage level.
- 4) Approach the ground up to the distance of 20cm holding GUN and see the high-voltage display drop.
- 5) Pull the GUN' trigger.

The high-voltage indicator begins to operate

Check if the voltage level changes when the high-voltage adjustment handle is turned .

- 6) open MAIN AIR and supllly air



7) pull the GUN' trigger and open the CONVEYING AIR

The pressure gauge hand moves

Pull the gun s trigger close the CONVEYING AIR and open the DOSING AIR

The gauge shand moves .

If all factors suggeted above is alright , every is O K

Remove powder from the nozzle of gun by AUXILIARY AIR

Power supply and fluidizing air supply.

## 2. LOADING

open the lid

fill powder up to the hoper s handle level

colse the ld and assemble hose

If everything checks alrigh, the quipment is ready

Slightest abnormality requires preferring to the emergency –measure guide.

## →TEST OPERATION

### 1. PAINTING

\* CAUTION: Check if all the conducting material within 5 meters around powder booth are completely grounded

- 1) Check if the powder is fluidified
- 2) Turn on the powder switch
- 3) Face the gun to direction of BOOTH
- 4) Pull the trigger
- 5) Adjust the high voltage to the required level-the level can be monitored by a meter
- 6) Wait untl the first-spayed powder comes out completely dried.
- 7) Proceed with spraying object to be powder coated ..

### 2 Taking stop spraying measure

- 1) release the GUN S trigger
- 2) turn off the power switch  
as the powder is still fluid , you shouldnot adjust the amount of high voltage . Cleaning air and powder output.
- 3) Be sure to turn off the power switch and cut off air valve during lunch time or after sinishing work

### 3 Cleaning the powder hose

+ CAUTION: In case of prolonged unsue of equipment , the powder remaining in hose should be eliminate as follows:

- 1) take our injector s hose coupling part from the hopper
- 2) Turn the GUN to the direction of BOOTH
- 3) Attach the AIR GUN tightly to the hose entrance and blow into it
- 4) Reassemble it

## **FLUIDIZING POWDER**

### **A .Fluidizing powder**

The fluid state of powder is closely related to powder type , water content of compressed air and outler temperature

The fluidizing proceds independently of control functions

- 1 .Keep the hopper s lid open
- 2 Slowly increase the fluidzing AIR –the powder begins the boil mildly, AIR in the hopper and adjust to the minimum amount of AIR for uniform boiling
- 3 close the lid

### **B . The amount of powder output and control**

The amount powder output is determined by powder type , the length and diameter of hose , and the amount of CONVERYING AIR and DOSING AIR.

1. check the powder is normally fluidizied
2. turn on the power switch
3. pull the trigger with the GUN facing to the direction to BOOTH
4. Open the CONVERYING AIR
5. Adjust the DOSING AIR

Turn slowly regulator of dosing air to clock wise from maximum counter clock wise pulling trigger until powder puffing is getting to normal injection

## COLOR CHANGE

### A. Changing powder color

- 1) Clean the outlet hose hopper completely
- 2) blow into the powder hose with compressed air
- 3) clean the GUN
- 4) put the powder to be used into hopper and finish all the preparation jobs
- 5) turn and spray the GUN toward BOOTH momentarily before the work begins

### B. How to manage

Routine maintenance of equipment prolongs product life and keeps its performance uniform

#### 1. Daily check -----INJECTOR cleaning and INSERT SLEEVE worn-down

.....POWDER HOSE cleaning

.....GUN cleaning

#### 2. weekly check ....cleans the hopper , injector and GUN

..powder should not be put in the hopper just before work

.....check the ground line between CONTROL UNIT , BOOTH and CONVEYOR

.....After checking air dehydrator , any water in it should be removed , the air ,but for checking the presence of moisture in it

### C. Checking for shutdown lasting 2-3 days

- 1) Turn off the power switch
- 2) Clean the CONTROL UNIT
- 3) Remove the input air and put it away
- 4) check above -1 .Daily check
- 5) Remove powder from HOPPER

## Comprehensive regulation

Workpieces type	Output voltage	1 <sup>ST</sup> air	2 <sup>sec</sup> air	Painting distance
Big size new	80-100kv	4-6kg/cm <sup>2</sup>	2-3kg/cm <sup>2</sup>	15-20cm
Corner, sides	40-60kv	2-3kg/cm <sup>2</sup>	0.5-1 kg/cm <sup>2</sup>	10-15cm
repaint	20-30kv	2-3kg/cm <sup>2</sup>	0.5-1kg/cm <sup>2</sup>	15-20cm

# CLEANING

## A. Hopper

1. Remove fluidizing AIR LINE
2. Remove injector
3. take our suction pipe
4. wipe the electric line , AIR HOSE .and powder hose cleanly with cloth
5. wipe the suction pipe clean
6. empty the remaining powder from hopper
7. clean the hopper s inner wall ,especially the bottom part , with vacuum cleaner
8. wipe the hoppers inner surface with clean cloth
9. replace the hopper to the original postion

CAUTION: the hopper must not be filled with powder unit work begins , Above all , the hopper s inner surface must not be cleaned with thinner or water

## B. Manual powder Electrostatic GUN

Rountine cleaning of GUN ensures trouble –free operation and normal function at all times.

Daily clearning

1. Remove the powder hose from gun
2. remove nozzle from GUN and clean it
3. Clean the gun s powder outlet with AIR along the direction of its flow
4. clean the gun s body with AIR
5. Assemble it

## C. Spray Nozzle

Dairly cleaning

----clean the outer surface of nozzle with compressed air (Do not use thinner or other liquild for clieaning)

...Clean the nozzle s inside with compressed air after removing it . The powder accumulated in the GUN must be removed.

....check if the nozzle is worn down

Check if the compressed air s oil and moisture are completely removed

## D .Injector

1. Disconnecting powder hose
2. Remove sleeve holder
3. Clean sleeve and inside of injector body.

## TROUBLES

Problem	Cause	Measure
High –voltage display does not operated even after powder is on and trigger is pulled	<ul style="list-style-type: none"> <li>. Electric faulty-The electric line coming into CONTROL UNIT is not property connected</li> <li>. Faulty fuse and bad equipemnt on the part of external power source .</li> <li>.Faulty lamp.</li> <li>.Faulty printed circuit board(PCB)</li> <li>.Faulty line in GUN</li> <li>.Faulty in high-voltage generation part</li> <li>.Faulty trigger switch</li> </ul>	<ul style="list-style-type: none"> <li>. connect the power</li> <li>Replace</li> <li>Preplace</li> <li>Preplace</li> <li>Preplace</li> <li>Preplace</li> <li>Preplace</li> <li>Preplace</li> </ul>
The powder would not be fluidized	<ul style="list-style-type: none"> <li>.The fluidizing air hose is not connected or compressed air is not input</li> <li>. Faulty fluidizing plate</li> <li>. Faulty operation of pressure reduction valve</li> </ul>	<ul style="list-style-type: none"> <li>.Connect after checking</li> <li>.Replace</li> <li>.Replace</li> </ul>
The gauge hands of CONVERYING AIR and DOSING AIR do not move during operation	<ul style="list-style-type: none"> <li>.operation mistake:</li> <li>The power switch is not pressed</li> <li>.The trigger is not pulled</li> <li>.Faulty SOLENOID valve</li> <li>.Faulty PCB</li> </ul>	<ul style="list-style-type: none"> <li>. Turn on the power switch</li> <li>.Check while pulling the trigger</li> <li>. Replace</li> </ul>

Problem	Cause	Measure
The powder would not be ejected even after power switch is on and trigger is pulled	<p>.Blockage generated in injector , check valve sleeve in the injector paint hose or GUN</p> <p>. worn-down sleeve</p> <p>.Poor fluidfying operation</p> <p>.CONVERYING AIR is not supplied.</p> <p>. Faulty air –adjustment valve</p> <p>. Faulty solenoud valve</p> <p>. Faulty PCB</p> <p>. Oil and moisture contained In the compressed air</p>	<p>. Disassemboe and clean</p> <p>. Replace</p> <p>.Replace</p> <p>.check above issues</p> <p>.Replace</p> <p>.Replace</p> <p>.Replace</p> <p>.Install an air dehydrator</p>
Powder is ejected from GUN but with its electrostatic intensity low	<p>.High-voltage assembly is low</p> <p>.Faulty GUN connector , wire and wire connector</p> <p>.Faulty PCB</p> <p>.Faulty high-voltage casecade</p> <p>.Faulty ROD holder</p>	<p>.increase the voltage leverl</p> <p>.Replace the faulty part</p> <p>.Replace</p> <p>.Replace</p>
Powder ejection and electrostatic intensity is good , but its attach efficiency is poor	<p>.Faulty earth of powder object</p> <p>.Too much paint on the conveyyor hangar and powder object area</p> <p>.The high voltage pin caved in</p>	<p>.Check the earth state</p> <p>.Remove powder from handar and powder-object area</p> <p>.Replace the rod holder</p>