

## **Off Road Model ESOI**



## **Improved Appearance**

1. **New design handle steering mechanism.** It is made of whole molding aluminum alloy. It is more beautiful. It is easy to turn around because of its handle designed as ergonomic.

2. **New wheel and tire.** It is made of Superior integrated aluminum magnesium alloy wheel and shock-absorb tire.

3. **New fender with bracket.** It seems more strong.

4. **With front light and back light.** Scooter can be driven in light and have alert function.

5. **New model pedal.** It is made of whole molding silica ge. which make scooter body more stable. Its waterproof and dustproof function is improved. It is more stable and safe for driver's standing because of its increased friction by grain.

6. **LED battery display.** It show battery by percent, scooter seems more direct and simple.

7. **Without key hole.** It is unlocked by remote control. It is more easy to operate and more safe to protect scooter.

8. **Axis of body is added 20 mm.** The proportion of length and width is more reasonable. It is more easy for turning.

## **Improved performance**

1.**New imported driving motor and transmission mechanism.**It is 36V,more powerful.The capacity of driving is increased by40%.It is easy to drive on sand or mountain and climb slope.

2.**Powerful algorithm,**with high power motor,the max speed is improved,which make driver more faster.

3.**Imported transmission gear.**It has no noise during driving.The noise is the lowest compared with other similar scooter.

4.**New sound and siren alarm function.**It has anti-burglary siren alarm,over speed alarm,and alert alarm.Which make driver drive more safe.

5.**GPS function is optional.**It can be added GPS model as request.It can improve management of rental.

## **New feature of ES01:**

- 1.LED battery display by percent,driver can know battery well.
- 2.Lock/Unlock by remote control,making scooter more safe.
- 3.Default horizontal position.making driver start more convenient.
- 5.Three Speed Mode Switching,suiting different driver driving.  
Default Mode:max speed 20km/h  
Beginner Mode:max speed 8km/h
- 6.Pull mode:easy to pull scooter when battery will run out.
- 7.Siren alarm.Scooter will make sound alarm when people drive it without unlocking.
- 8.New steering mechanism, giving a much more stable ride and a faster response
- 9.Updated processed motherboard, making it safer and easier to control.
- 10.Waterproof, pedal and charger jack cover.
- 11.Advanced design for steering and handling, the overall look is a big improvement.
- 12.It has a light exquisite steering mechanism, enabling a more flexible turning circle.
- 13.The new model has 4 floor detectors, improving the safety and stability, as a result the rider will not fall.
- 14.Adjusted big power motor.Max power can achieve 1600W overall,

making it easy to climb continuously on a 30 degree slope.

15. A siren alarm sounds as a reminder to the rider as of the state of scooter

16. GPS tracking is optional

17. High quality wheel with tires to suit off road.

## Frame of ESOI

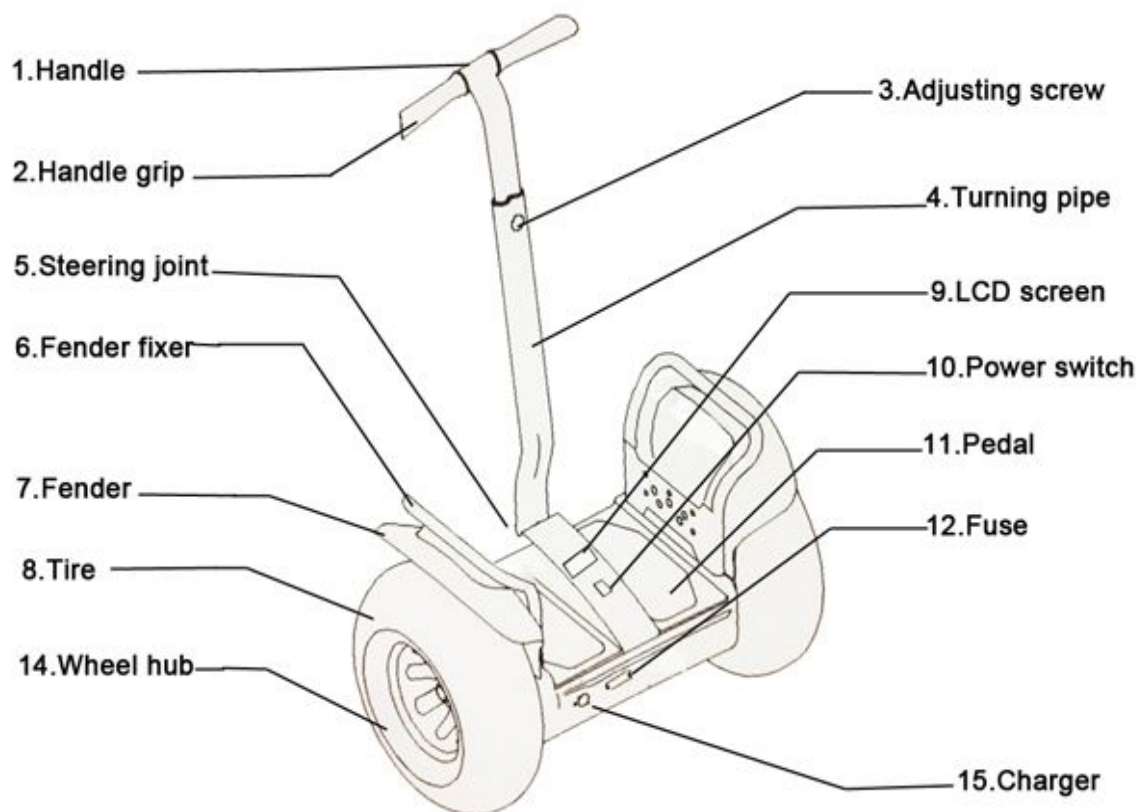

## Parameter of ESOI

Parameter	Standard kits/parts
Max cruise speed :20 km/h	Handle: 1 pc
Dimension:45×87×60 cm	Remote Control: 2 pcs
Max load :125kg	User manual: 1 pc
Battery : 3 lead acid	Driving handle:1 pc
Motor:Two imported DC Motor,DC servo drives	Spare fuse: 4 pcs
Wheel:Superior integrated aluminum magnesium alloy	Battery:3 pcs
Tire: 19*7-8inch shock-absorb tire	Battery Charger:1 pc
Height of footplate:26cm	Fender: 2 pcs
Net Weight:62 KG	Tire: 2 pcs
Max. Mileage :about30km, depends on driving skill and road condition	Bracket: 2 pcs

DESCRIPTION	Green product (Electric, healthy)	
	No pollution and zero consumption	
	CE & ROHS & FCC certification	
SPECIFICATION	Net Weight	62 kg
	Dimension	91*54*72 cm
	Max cruise speed	20km/h
	Max load	125 kg
	Max. Mileage (after full charging)	30-35 km
	Max climb capability	30 degree
	Min turning radius	0
	Charging time	8 h-10 h
	Battery	PB, 3 * 12V @14Ah
	Power	Two imported DC Motor, DC servo drives
	Voltage	100 v-240 v
	Max Power	1600 watts (2*800w/pc)
	Lifetime of battery	1-3 years
	Tire	19*7-8inch shock-absorb tire
	Wheel	Superior integrated aluminum magnesium alloy
	Height of handle	80-110 cm adjustable
	Height of footplate	10in / 26cm
	Specification of footplate	11.5×25 in / 16×40 cm
	Max. Height above ground	13 cm
Standard Pressure	250 kpa	

# Escooter

Shenzhen Xinli EscooterTechnology Co., Ltd

---



Web: [www.xinlitech.net](http://www.xinlitech.net)

Email: [sophia@xinlitech.net](mailto:sophia@xinlitech.net)