

Changzhou Xionghua Tongtai Automation Equipment Co., Ltd



User's Guide

Variable Frequency and Constant-pressure Water Supply Controller

CPC-2/3/5

In the past, the control core of the constant-pressure water supply are usually composed of programmable controller and the pressure difference transducer and this combination has few functions (only the professional programmer can change the dates), and the simple algorithm can not adapt to various type of water supply and working status. And it is big size, high cost, and complex debugging, combined with two independent units.

CPC-series controller is a new type programmable controller. It is like the 'AC contactor' in the cabinet of frequency water supply, easy to operate, convenient to connect and the user can easy to understand the principle of constant-pressure water supply by an AC drive.

Functions:

1. Intelligent switch between the two kinds of pressure (living water and fire-fighting water)
2. Automatically alarm when the external pool has no water, and the pump drawing vacuum
3. Multiple small-flow modes are optional
4. Delay to open the increasing pump, delay to close the decreasing pump
5. Built-in PID control
6. CPC-5 controller has double pressures control (inlet and outlet pressure) with COM port (double ports).

After connecting with touch-screen, user can monitor and modify the parameters on the touch-screen and another port can connect with the computer to realize remote control.

Main performance and feature

Input

4-channel digit value input (dry contacts)

1-channel analog value input is usually electric resistance signal of remote pressure gauge (4-20mA current signal or 0-5V voltage signal, whether current signal input or voltage signal input need to be selected when the custom buy the controller)

Output

1-channel analog value output (the frequency converter supply the power and the power sources between controller and frequency converter is completely isolated)

8-channel digital value output

Date settings

The user can open several programmed functions (refer to the function table). These functions include the parameters the constant-pressure water supply system in different working condition. According to different working condition, program the function to reach the best working status.

Operating: according to the function table, with no the professional program knowledge, the user also can set the parameter.

Reliability: the system adopts high-performance and single-chip integration system with power-off storage and it is reliable and stable in operation. In theory, the power-off memory can remain for one hundred and the read-write times are more than 1 million.

Proper design: the pump works on the principle that which pump opens first which one will close first. With small flow work mode, the system is more stable and saving energy.

CPC-2/5 is mounted into the cabinet, CPC-3 is mounted on the cabinet, their functions have no difference.

CPC-5 is mainly used to control the water supply equipment with no negative pressure, comparing with

CPC-2/3, CPC-5 has more functions and more flexible application.

Feature:

- 8-channel digital value input
- 10-channel digital value output
- 2-channel analog value input
- 1-channel analog output
- Double communication port

The description of the panel and terminal
picture 1

Panel layout and terminal

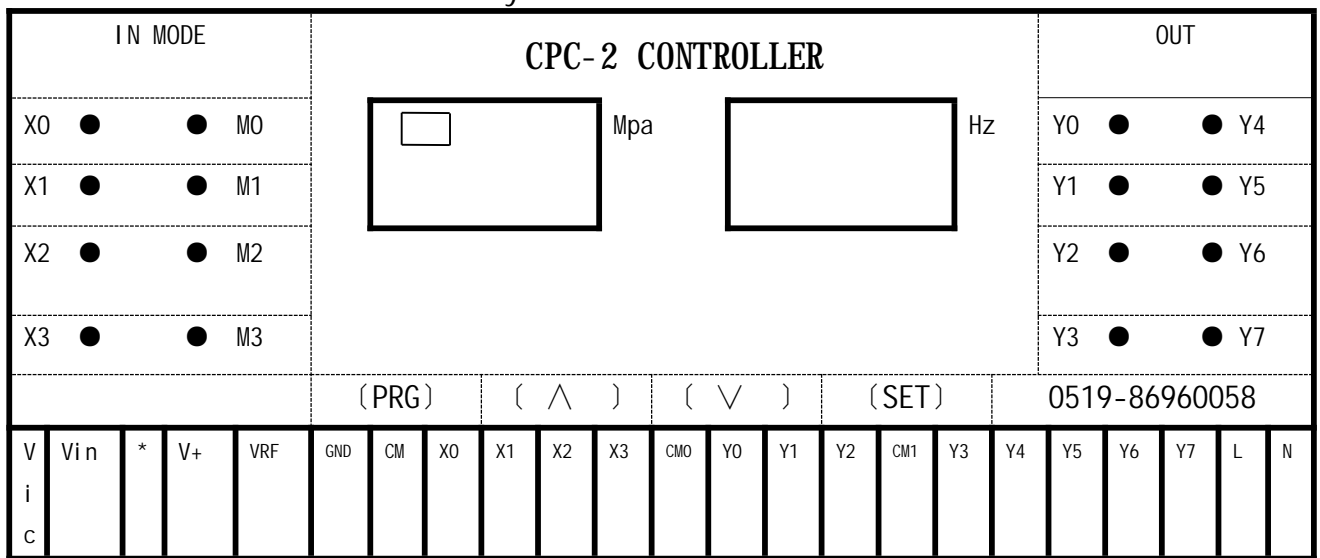

Panel (picture 1)

Operation panel and terminal

- A. Left display (three-digit): show the pressure (Mpa) at work status and the dates at the set status.
- B. Right display (two-digit): show the frequency (Hz) at working status and the function code at the set status.
- C. XO-X3 indicator: indicate the status
- D. MO-M3 indicator: indicate the work mode
- E. YO-Y7 indicate: indicate the effective output
- F. PRG: normal display/ programming mode selection
- G. ^/V: set the date up/down '1', if press and hold, the date will continuously increase/decrease.
- H. SET : move the setting cursor/ confirm the setting. Select the 'function code', or 'value'. Press and hold on the button to confirm the function code or the setting value.

Connecting terminal and the terminal function

- A. L、N: 220V AC, 50Hz
- B. VCC、VIN、* : analog value of pressure signal input terminal, connecting with remote pressure gauge. (Attach connection diagrams of 4-20mA current signal, two different signal sources)

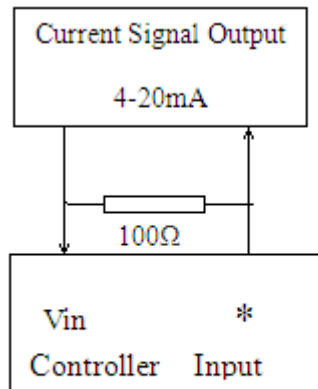

the external input of the controller
the connection of current signal

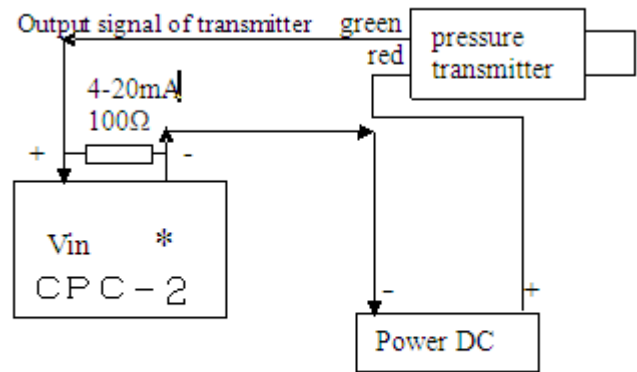

the connection of two-wire system transmitter

C. CM, XO, X1, X2, and X3: digital value input

D. V+, VRF, GND: analog value (control signal) output, connected with the frequency setting terminal of the transmitter.

E. CMO, Y0, Y1, Y2 and CM1, Y3, Y4, Y5, Y6, Y7: digital value output terminal

(CPC-2 CPC-3) the indicator X0-X3

1. XO - increase opening pump: the indicator light will blink before the delayed time of increasing opening pump, and it will light on all the time after the delayed time.
2. X1- decrease opening pump: the indicator light will blink before the delayed time of decreasing opening pump, and it will light on all the time after the delayed time.
3. X2- small-flow pump: the indicator light will blink when the small pump start and it will light on all the time when the small pump stop.
4. X3- fault indicator: it will blink at fault, and the right display will alternatively show the fault codes and the frequency of the converter (because the pumps stop, the actual frequency will is 00Hz)
5. MO- the work status of civil pressure
6. M1- the work status of fire-fighting pressure
7. M2- the selection state of function codes
9. M3 - the value modifying state

Note: the input terminal of CPC-5 is more complex and the accuracy is higher. The panel is also different.

programming and date setting

Before the CPC serial are sold out, the function codes has been factory default, which can usually meet common control system. The following the method of changing the factory default.

1. Enter read-only state: the values just can be read but not changed

- ① press PRG for 3s, the M2 will blink and the right display will show the function code (the last digit will blink),press ‘^’and ‘V’ to select the function code, and the value corresponding the function code will be read.
- ② After viewing the values, press ‘PRG’ for 3s to return to the normal work state.

2. Enter the modifying state

- ① To avoid changing by others, the user must input the correct password to enter modifying state.

The factory password: function code F00 - 254, F01 - 02

② Press PRG for 3s, the M2 will blink and the right display will show the function code (the last digit will blink), press 'SET', '^', 'V' to select the function code F00 - '254', F01 - '02', the select other function codes to modify the values.

③ press ^/V to select the function code, then press 'SET' to enter the value modifying state, and M2 will be out and M3 will blink, the left display shows the old value(the last digit is blinking). Press 'SET' to move the cursor and press ^/V to up/down the values.

④ after setting the values, press 'SET' for 3s to confirm the new values, M3 is out and M2 is blinking to wait other operation (the last digit of the function code is blinking)

⑤ Repeat step ③, ④ to modify other values and press 'PRG' for 3s to enter the normal work state and M2,M3 are both out

⑥ the above setting can refer to the table 1

Troubles and Measurements

Trouble and Measurement Table 2

Alarm display	content	Check item	measurement
Err—A1	The pump normally stop	Is there stopping signal	Clear the external shutdown signal
Err—E1	Frequency converter error	Whether the frequency converter alarms	remove the error of converter (check the output signal NO/NC (normal open/normal close))
Err—E2	The external pool has no water	Whether there is water in pool	Whether the value corresponding F25 is correct
Err—E3	The pumps draw vacuum	Check whether the pumps have water; whether the pressure gauge has the pressure signal	Remove the error of pumps: check the remote pressure gauge, change the gauge, the value corresponding F23 is too big
Err—E4	Over-pressure make the pump stop	Check function code 30,whether the pressure value is too low	Reset the function code 30, whether the pressure gauge is broken-down
Err—EA	The writing operation is prohibited		Check whether the password of F00 and F01 is correct
The pressure is under the setting pressure, the frequency converter		Whether the displays of pressure gauge controller are as same as the pressure gauge	Adjust full F05 to make the display of the pressure gauge coordinated with the display of controller
		Whether the displays of the controller are as same as the frequency	Adjust full F06 or adjust the 'frequency gain' of the inverter to make the frequency of the inverter as same as the display of the controller

		of the inverter	
The pressure exceeds the setting value		Whether there is water in the pipe at first turning on; The delay time of increasing open pump is too short	Manually open the pump to fill the pipe and prolong the delay time of increasing open pump F12
Pumps switch frequently		The frequency is inconsistent.	Reset.
		reverse in variable frequency and forward in power frequency	Check the connection line and phase sequence
		The check valve leaks	Eliminate the leakage
		The time setting of acceleration and deceleration is wrong	Recheck and reset the time of acceleration and deceleration
The frequency alarm after adding pump	frequency alarm	The time of acceleration and deceleration is too long	The deceleration time of the inverter is less than 4s

The description of function codes

1. F00,F01 password

To avoid the dates being changed by others, the user must enter the password when modifying the dates.

(Refer to Function Table)

2. F02, civil pressure setting (M)

It is the user actual pressure; the user can set the pressure according to the actual situation. 0-225 → 0-2.55Mpa

3. F03 fire-fighting pressure setting (X)

It is the second pressure, which can make 'civil pressure' and 'fire-fighting pressure' switch through the external input signals. It is mainly used for the equipments of fire-fighting and civil or it is used for 'civil pressure'/'fire-fighting pressure' as the regulated pressure.

4. F04 adjust pressure zero(B)

F05 adjust pressure full (K)

Adjust the value of the pressure gauge as same as the display value of the controller

Due to the difference of the zero value of pressure gauge (caused by the inconsistent linearity of the variable resistance) and to get the correct display value(Y), (B) value and (K) value must be adjusted. $Y=KX-B$ operational formula, (X) is the resistance signal the pressure gauge outputting

5. F06 : adjust frequency full(f)

Adjust the frequency display of the controller as same as the frequency display 'VF' of the frequency

converter (VF- the operating frequency of the converter)

The operational formula 'VF' = (f)*(N), (N) is the frequency the controller displayed.

6. F07, the frequency of the small-flow pump entry (F)

F08, the pressure of the small-flow pump entry (P)

F09, the time of the small-flow pump entry

F10, the mode of the small-flow pump entry

The small-flow pump mode of entry is the function when the system is at small flow.

When the flow of the water supply system is small, the discharge pressure of the pump is the same as the pressure of the external pipe network, making the frequency do work uselessly. To solve the question, it is needed to find the frequency point 'Q' through field debugging. If 'F' < 'Q' and 'P' < 'actual pressure', the master pump will stop working and the small pump will start to work after the delay time of 'the time of the small-flow pump entry'. The work type of the small pump depends on 'the mode of the small-flow pump entry'.

7. F11, delay the time of the small-flow pump exit

It is the delay time function when the exit condition of the small-flow pump is reached. (Refer to chart 3)

After 'delay the time of the small-flow pump exit', the small pump will stop working and the master pump will start to work.

8. F12, the delay time of increasing the opening pump

The master pump works at variable frequency of 50HZ, but the pressure can not reach the set value, then delay open the second master pump, and so on, the delay time of the 3rd, 4th delayed to open.

8. F13, the timeout of the variable frequency after increasing to open pump

It is the interval time of the variable frequency. The variable-frequency pump will work at power frequency mode but not variable frequency mode, and the increasing pump will work at variable frequency mode.

9. F14, the delay time of decreasing the open pump

It is the delay function. Under multiple pumps working, when the pressure exceeds the set value, delay time to decrease the number of the open pumps.

When the frequency of the variable-frequency pump is lower than the value of F20, it will start to delay and when the time is reached, one power-frequency pump will stop working

10. F15, raise the frequency quickly after decreasing the pump

when the power-frequency pump stop working, the frequency of the variable-frequency pump will raise quickly.

The frequency of the variable-frequency pump is low when the power-frequency pump stop working and this will lead to the pressure fluctuation of the pipe network, so this function will reduce the fluctuation as small as possible.

11. F16, the work time of the pump in turn

F17 the work time unit of the pump in turn

It is the function of setting the work time of the pump in turn. The rotation work can reduce the load of every pump to prolong the life of the system. The time unit of the rotation work time is second, minute, hour (for example, F16-'8', F17-'2', it means the pumps take turns to work every 8 hours)

12. F18, the upper limit of the small-flow pumps working at power frequency

F19, the lower limit of the small-flow pumps working at power frequency

It is the upper and lower limit of the small-flow pump electric contact

When F10-'2', the function of F18, F19 is used, (refer to Chart 2 and Table 4)

13.F20, the frequency when the pumps have no water

It is the judging function. When the frequency is low, the pumps need to be closed. At low frequency state, the pump has no water, so start to time for decreasing pump.

14.F21, the accelerating time when the pump has no water

Control the pump rotary speed from '0HZ' to 'the frequency when the pumps have no water'

15.F22 the acceleration time of the pump discharging

Control the acceleration time of pump rotary speed from 'pump no discharge frequency' to '50HZ'

16.F23, the pressure when the pump has no water

F24, the entry time when the pump has no water

It is the judgment condition of alarm when the pump draw vacuum.

After the pump starting to operate, if the pressure is always lower than 'the pressure when the pump has no water' and the time exceed 'the entry time when the pump has no water', the controller will alarm, 'E3' is the alarm judgment when the pump draw vacuum.

17. F25, the selection of input point (NO) or (NC)

It is the selection function of input type (refer to Chart 5)

18. F26, the selection of preventing self-locking and not self-locking

It is the selection function of fire-fighting signal (contact type, hold type)

19. F27, the delay time of variable frequency becoming power frequency

It the interval time when the variable-frequency pump stop, the power-frequency pump start to working

20. F28, the work time for antirust

It is to prevent rust and lock rotor when the pumps don't work for a long time. It is necessary for pump to work for several seconds or minutes in short time.

21. F29 , remain

22. F30 , the pressure, when the pipe exceed the pressure, the pump will stop

The function can prevent the pipe from breakdown due to the over pressure

23.F31, factory initialization

Restore the factory set

24.F32, remain

F33 depends on F32

25.F33 the selection of feedback modes

The pumping mode is positive feedback and the water supply mode is negative feedback

26.F34, the lower limit of the pump working frequency

27.F35, external control pressure 1

F36, external control pressure 2

F37, external control pressure 3

F38, external control pressure 4

28.The function after F38 is defined according to user's requirements

The principle of the system

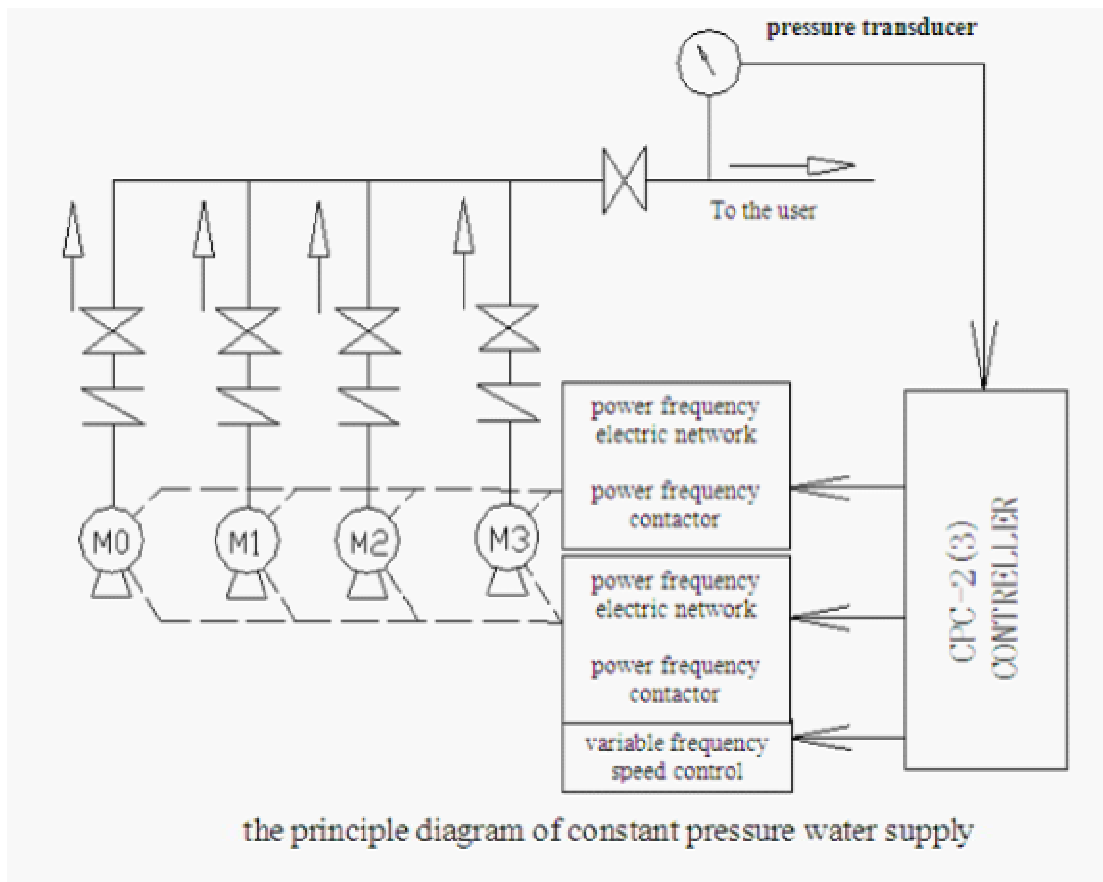

The work process : example

The work process of 4 pumps (the discharge of one pump is 10t/h)

	1	2	3	4	5	6	7	8	9	10
state	0-10t/h	10-20t/h	20-30t/h	30-40t/h	40t/h	40-30t/h	30-20t/h	20-10t/h	10-0t/h	small flow
Pump 1	variable frequency	Power frequency	Power frequency	Power frequency	Power frequency	Power frequency				
Pump 2		variable frequency	Power frequency	Power frequency	Power frequency	Power frequency	Power frequency			
Pump 3			variable frequency	Power frequency	Power frequency	Power frequency	Power frequency	Power frequency		
Pump 4				variable frequency	variable frequency	variable frequency	variable frequency	variable frequency	variable frequency	

The selection of mode and mounting size :

1. The model naming of CPC series

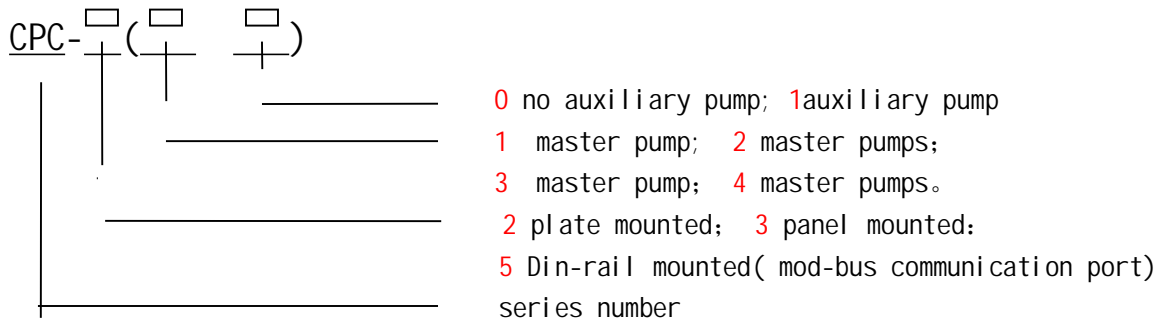

2. dimension size

- CPC-2: Size 200*90*80 Mounting type: fix on the plate
- CPC-3: Size 150*75*130 Mounting type : mount on the panel of the cabinet
 Perforate size 150*75
- CPC-5: Size 154*100*110 Mounting type : din-rail mounting

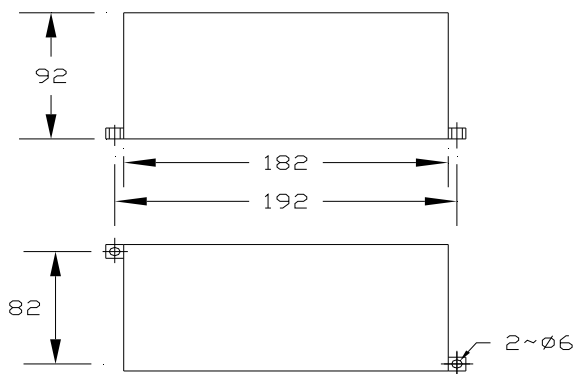

CPC-2 external dimension

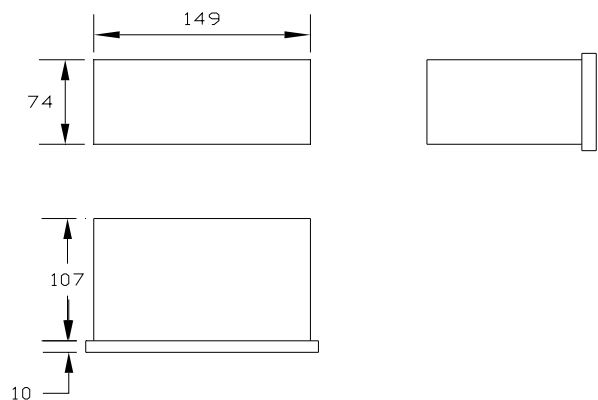

CPC-3 external dimension

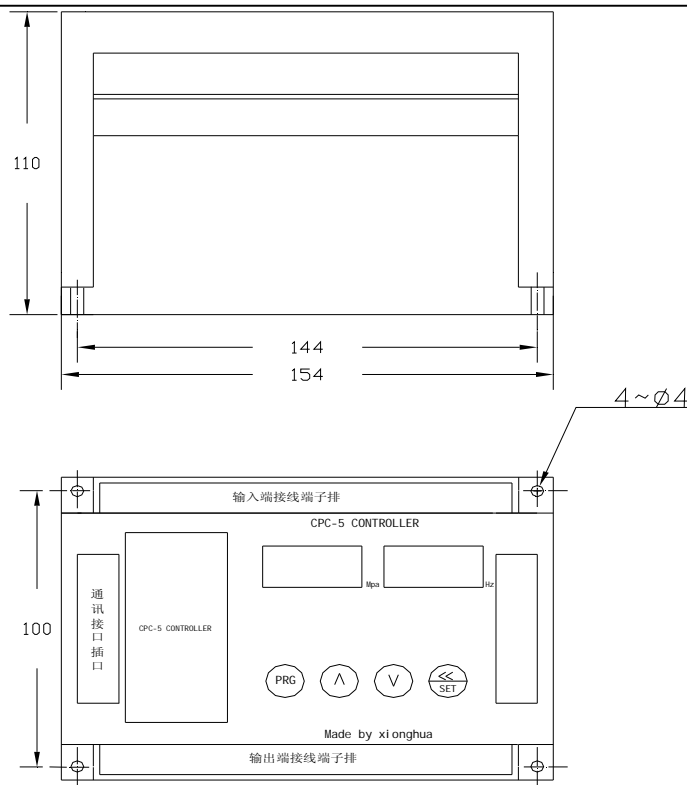

CPC-5 external dimension and panel drawing

Ordering information

If you need the controller, please fill in the form and contact us.

pressure signal type	current signal		current signal		tele-transmission pressure gauge	
output signal	transistor output			relay output		
Pumps Nos	1			2		
	3			4		
Auxiliary pump	yes			no		
communication	yes			no		

Test steps:

After the installation, set first according to the following steps

1. Set the display of the controller and the display of the pressure gauge coincident (full adjustment and zero adjustment of pressure)
2. Set the controller working frequency coincident with the displayed frequency of the converter (adjust the frequency full or increasing the internal input signals of the converter)
3. Set the user pressure (civil pressure)
4. Set the date of small flow (Chart 3)

Chart 1
Setting parameters and the panel display

NO	Operation	display	instruction
—	Only-read operation		
1	Power on	X.XX XX	Running status
2	Press PRG for 3s	OOO O <u>O</u>	the last digit of the right display will blink,which can can be modified
3	Press ^/∨	XXX XX	display the date corresponding the function code
4	Press PRG for 3s	X.XX XX	Return to the running status
— —	Set password and modify the dates		
1	Power on	X.XX XX	Running status
2	Press PRG for 3s	OOO O <u>O</u>	the last digit of the right display will blink,which can can be modified
3	Press SET for 1.5s	00 <u>0</u> 00	The last digit of the left display will blink
4	Press ^	00 <u>4</u> 00	The date of F00 is '004'
5	Press SET and ^	0 <u>5</u> 4 00	The second digit is '5',and the date of F00 is'054'
6	Press SET and ^	<u>2</u> 54 00	The first digit is '2', and the date of F00 is '254'
7	Press SET 1.5s	254 O <u>O</u>	Return to the selection state of function code, the last digit of the function code blinks which can be modified
8	Press ^	OOO O <u>1</u>	The function code is F01
9	Press SET 1.5s	OO <u>O</u> 01	Set the date of F01, the last digit of left display blinks which can be modified
10	Press ^	OO <u>2</u> 00	Set the date '2'to enter the modified state of other dates
11	Press SET 1.5s	OO2 O <u>1</u>	After password set,enter other function code and modify the date
12	Repeat step 8 to 11 to enter other function codes and modify the corresponding dates. After modifying,press PRG for 3s to return the running status.		

Function Table

function code	name	range	unit	factory	user set	remark
00	password digit	0-255		00		254
01	password digit	0-255		00		02
02	civil pressure set	0-255	0.01 Mpa	40		
03	Firing pressure set	0-255	0.01 Mpa	60		
04	pressure zero adjustment	0-255	%	0		
05	pressure full adjustment	0-255	%	128		display the correction coefficient of the pressure
06	frequency full adjustment	0-255	%	180		correction coefficient of the frequency
07	frequency of small flow entry	0-50	Hz	36		Set value > actual stable value
08	Pressure of small flow entry	0-255	0.01 Mpa	30		Set value < actual stable value
09	Time of small flow	0-255	sec	90		When meet the condition 07/08, start timing, and when the time reaches, enter the small-flow work status
10	Work type of small flow entry	0-3		3		0-no pump 1- variable frequency 2-power frequency 3- no small flow
11	Delay time of small flow exit	0-255	sec	5		
12	Delay time of increasing open pump	0-255	sec	5		
13	The pause work time of frequency after increasing open pump	0-255	sec	5		
14	Delay time of decreasing open pump	0-255	sec	5		

15	Quickly reach the frequency after decreasing pump	0-50	Hz	40		
16	The work time of the pumps in turn	0-255	17	8		If there is the anti-rusting function,it is the anti-rusting time
17	The time unit setting of the work time of the pumps in turn	0-2		2		0-1s 1-1min 2-1 hour
18	Pressure low limit of the small-flow work	0-255	0.01 Mpa	50		
19	Pressure upper limit of the small-flow work	0-255	0.01 Mpa	42		
20	Frequency of the pump no water	0-50	Hz	25		
21	Acceleration time of the pump no water	0-255	sec	10		
22	Acceleration time of the pump watering	0-255	sec	30		
23	Pressure at no water	0-255	0.01 Mpa	5		
24	Time of no water inlet	0-255	sec	90		
25	Input contact NO/NC selection	0-15		11		Chart 5
26	Fire protection self-clock/no clock	0-1		0		0- no clock 1- self-clock
27	The delay time of the variable frequency switching to power frequency	0-255	0.1 sec	5		
28	Anti-rusting time	0-255	sec	10		
29	Remain					
30	The pipe pressure when the pressure exceeds the pipe pressure, pumps	0-9.99		0.8		Over pressure display E4

	shut down					
31	Factory initialization	0-255		0		0- no initialize 5- initialize
32	Remail					
33	Positive and negative feedback set	0-1		0		0-negative feedback 1-positive feedback
34	Pump work frequency low limit setting o			10		
35	External control pressure 1			40		The external input controls the setting pressure; when the actual pressure exceeds the setting pressure, the output points act(30,31,32,33)
36	External control pressure 2			40		
37	External control pressure 3			40		
38	External control pressure 4			0		
40	X0 input define	0-7		0		0-fire fight start 1-fire fight stop 2-frequency error 3- external shutdown 4- stop with no water 5- external control pressure 1 Optional: 6- external control pressure 2 7- external control pressure 3
41	X1 input define	0-7		4		
42	X2 input define	0-7		1		
43	X3 input define	0-7		2		
54	Y0 output define	0-23				Output points Y0-Y7 select: 0-1# pump variable frequency 1-1# pump power frequency 2-2# pump variable frequency 3-2# pump power frequency 4-3# pump variable frequency 5-3# pump power frequency 6-4# pump variable frequency 7-4# pump power frequency 10-small-flow output 11- frequency error output 12-fire fight signal output 16- alarm output with no water 17-upper and low limit output 20-adding pump signal output 21- decreasing pump signal output 23-small-flow signal output 30-33-compare output actions
55	Y1 output define	0-23				
56	Y2 output define	0-23				
57	Y3 output define	0-23				
58	Y4 output define	0-23				
59	Y5 output define	0-23				
60	Y6 output define	0-23				
61	Y7 output define	0-23				
62	Pumps total	1-4				When use single pump, set

	amount					62-1,63=1
63	Most pumps putting into use	1-4				

Function Table (Continued)

Function Code(F)	Name	Range	Unit	Factory	User Set	Remark
34	Pump work frequency low limit set	0-50	Hz	10		
35	External control pressure 1	0-255	0.01Mpa	40		The external input controls the setting pressure; when the actual pressure exceeds the setting pressure, the output points act(30, 31, 32, 33)
36	External control pressure 2	0-255	0.01Mpa	40		
37	External control pressure 3	0-255	0.01Mpa	40		
38	External control pressure 4	0-255	0.01Mpa	0		

CPC-5 the communication protocol address table

RS232 protocol

(CPC-5 adopts RS232 protocol, when RS484 communication is needed, it can be got through 232-485 conversion module)

communication dates

the dates length : 8 digits

ending digit : 1 digit

even-odd check : EVEN

communication baud rate: 9600/ bps

communication protocol : MODBUS-RTU

The communication address between controller and touch screen is following.

set the address character:

Function code +256

M0	Input X0	M1 0	Small flow signal	M2 0	Output Y4	M30	
M1	Input X1	M1 1	Fault indicator	M2 1	Output Y5	M31	
M2	Input X2	M1 2	Civil pressure indicator	M2 2	Output Y6	M32	ER-A1
M3	Input X3	M1 3	Fire-fighting pressure indicator	M2 3	Output Y7	M33	ER-E1
M4	Input X4	M1 4	Function indicator	M2 4	Output Y10	M34	ER-E2

M5	Input X5	M1 5	Setting indicator	M2 5	Output Y11	M35	ER-E3
M6	Input X6	M1 6	OutputY0	M2 6		M36	ER-E4
M7	Input X7	M1 7	OutputY1	M2 7			
M8	Signal of increasing pump	M1 8	Output Y2	M2 8			
M9	Signal of decreasing pump	M1 9	Output Y3	M2 9			

address	remark	property	address	remark	property
D10	Exit pressure	Only-read	D258	Civil pressure set	read/write
D11	Variable frequency	Only-read	D259	Fire-fighting pressure set	read/write
D12	Setting pressure	Only-read	read/write
D13	Entrance pressure	Only-read	D320	Y10 output definition	read/write
D14	Work time(the status not change)	Only-read	D321	Y11 output definition	read/write

chart 3 selection of small-flow work type

Function code 10	Work type	small flow application	the exit condition
000	no pump	There is only main pump but not small pump	The pressure is lower than the pressure of small flow entry
001	Variable frequency	The small pump runs at the variable frequency mode	The small pump runs at 50HZ, and the setting pressure can not be reached.
002	Power frequency	The small pump on/off power-frequency work according to the upper limit and the lower limit of the pressure(F18,F19)	After opening the small pump, the setting pressure still can not be reached.
003	no small flow	Not allow cutting off the water supply(for example, the circulating cooling water)	

Chart 4 the selection of work time in turn

Function F16	Function F17	Set readout valve of the work time in turn
8	2 (h)	8 h
30	1 (m)	30 minutes
60	0 (s)	60 s

Chart 5 F25 the selection of input points

	X0	X1	X2	X3		X0	X1	X2	X3
0	NC	NC	NC	NC	8	NC	NC	NC	NO
1	NO	NC	NC	NC	9	NO	NC	NC	NO
2	NC	NO	NC	NC	10	NC	NO	NC	NO
3	NO	NO	NC	NC	11	NO	NO	NC	NO
4	NC	NC	NO	NC	12	NC	NC	NO	NO
5	NO	NC	NO	NC	13	NO	NC	NO	NO
6	NC	NO	NO	NC	14	NC	NO	NO	NO
7	NO	NO	NO	NC	15	NO	NO	NO	NO

Note:

- l Please cut off the power when wiring, and give power after confirming all connections
- l Prohibit any reforms about the circuits and the internal parts
- l Store it at dry, free of dust and well ventilated environment
- l Protect it from corrosive liquid and air
- l For the common frequency converters connections with CPC-2/3,,please refer to the Picture 2 ~6(connections diagram and related parameters)
- l The mature connection diagrams, please refer to appendix picture 1-13
- l The manufacturer reserves the right to revise the product design, which is subject to revise without notice.

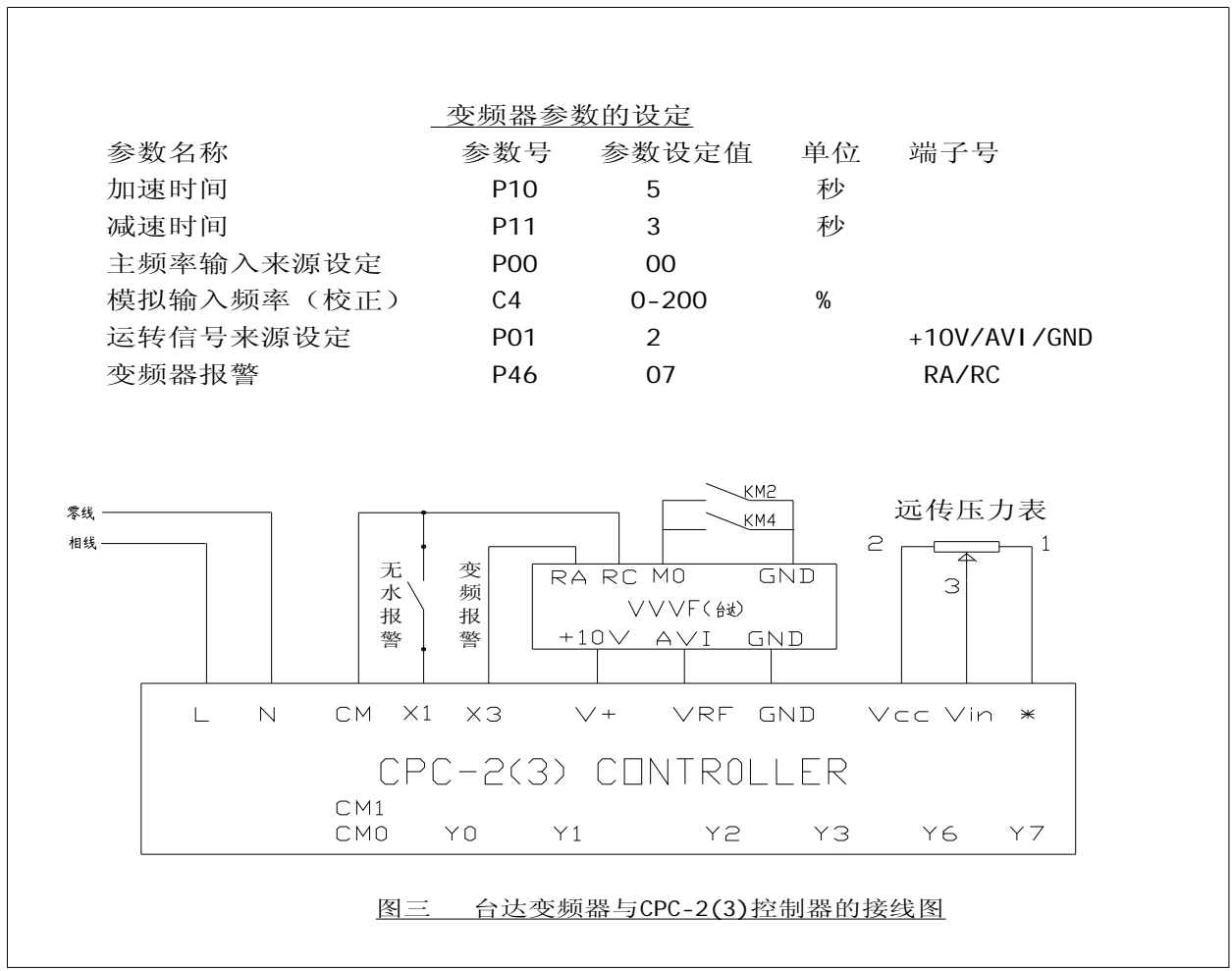
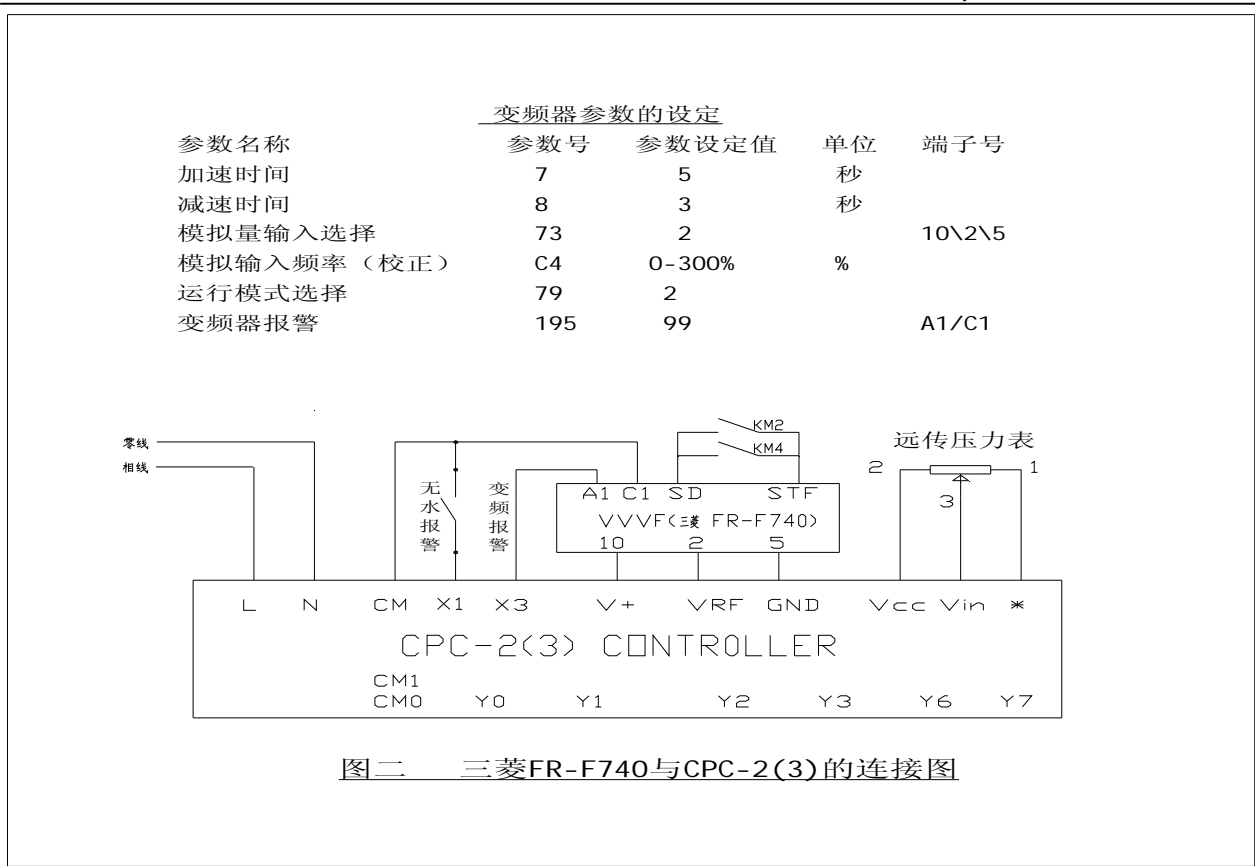

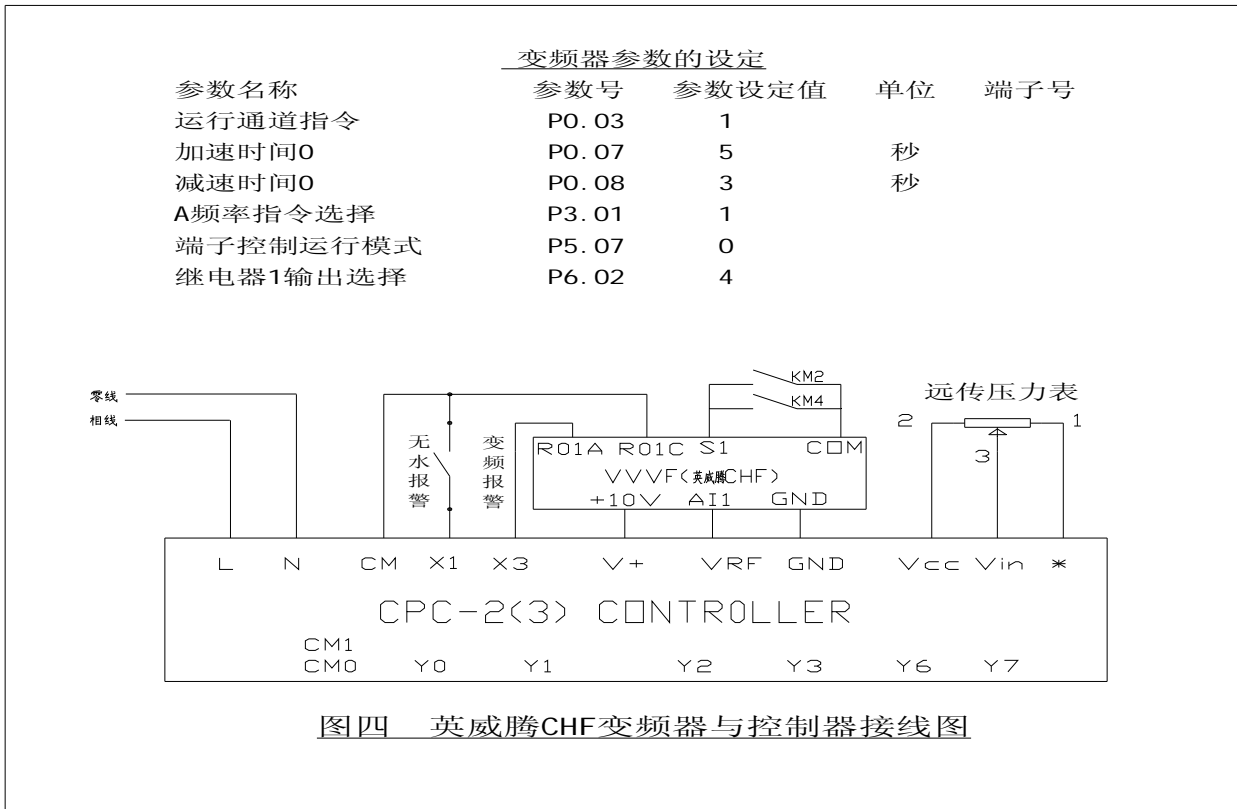

变频器参数的设定

参数名称	参数号	参数设定值	单位	端子号
EXT1 COMMANDS (外部1命令)	1001	DI 1		DI 1
加速时间1	2202	50	0.1秒	
减速时间1	2203	30	0.1秒	
外部输入频率 增益调整	1302			
REF1(给定1)	1101	1		
REF1 SELECT (模拟量信号源选择)	1103	2		
继电器1输出选择 (变频器报警)	1401	5		ROCOM/RONO

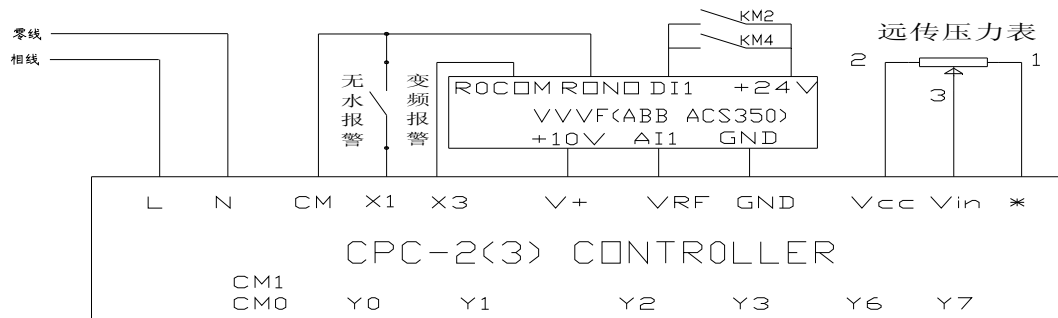

图五 ABB ACS350变频器与控制器接线图

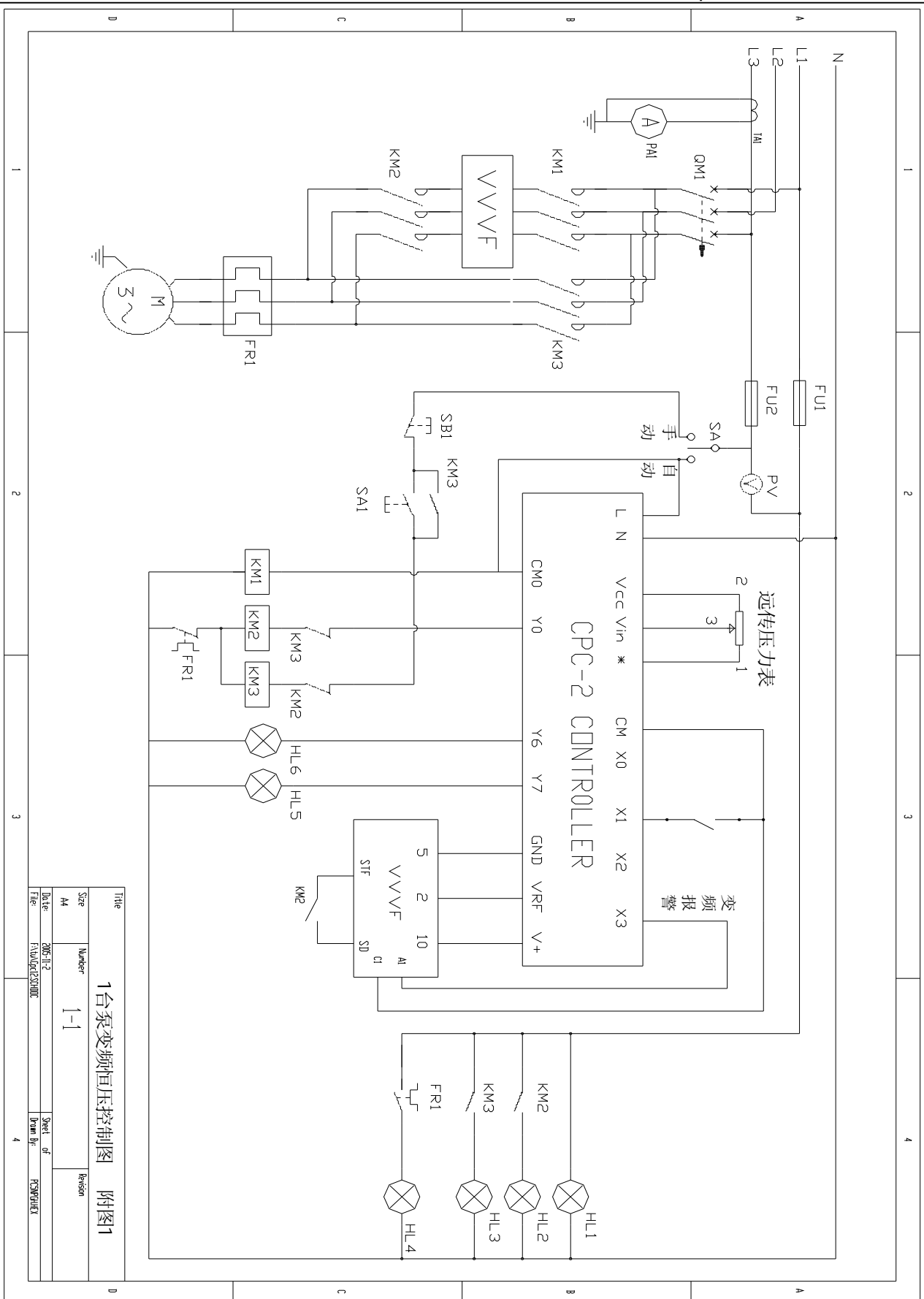

Title		1台泵变频恒压控制图 附图1	
Size	Number	Revision	
A4	1-1		
Date	2005-11-2	Sheet of	1/1
File	FWALDCE2005C	Drawn by	PCWPHHX

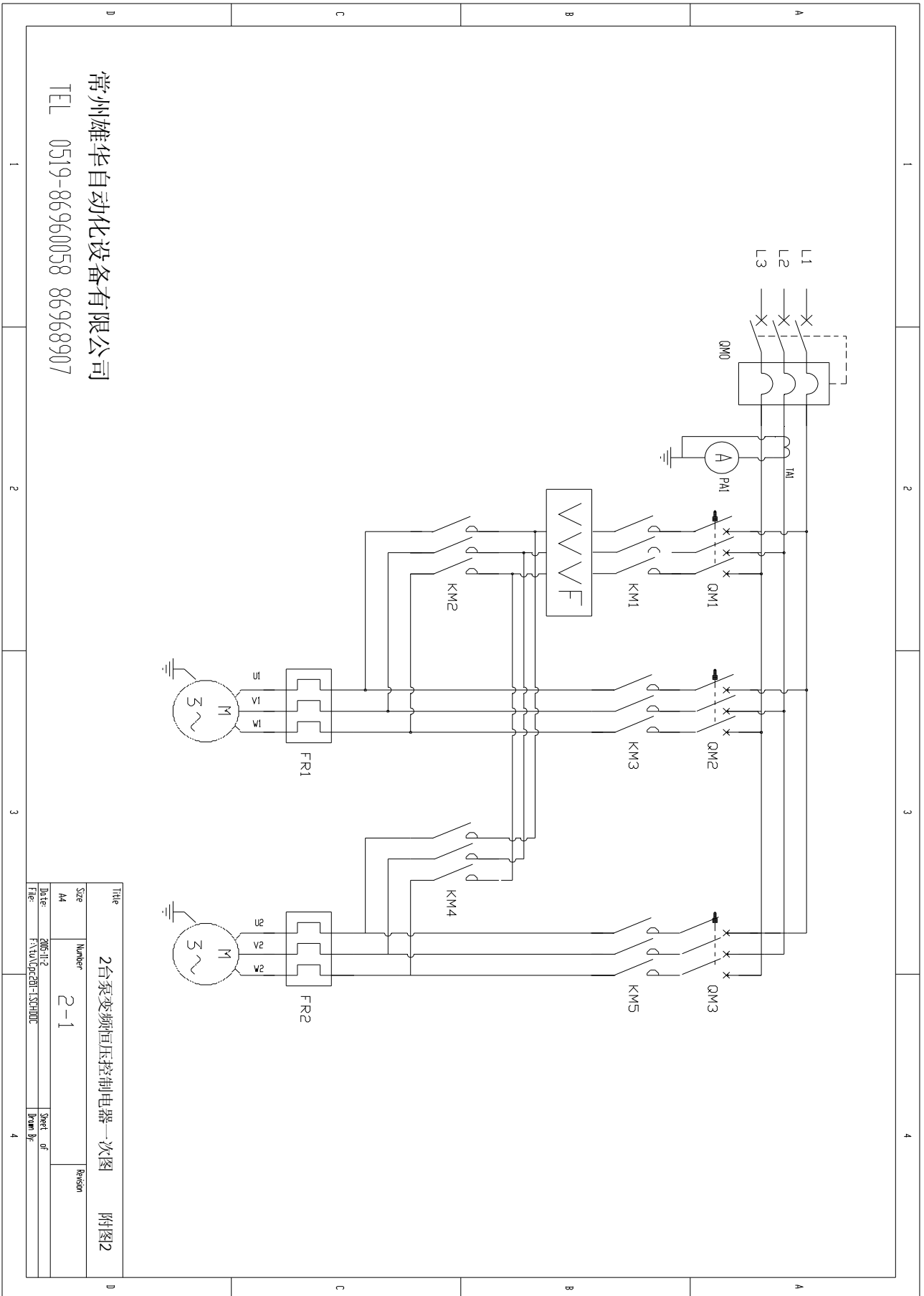

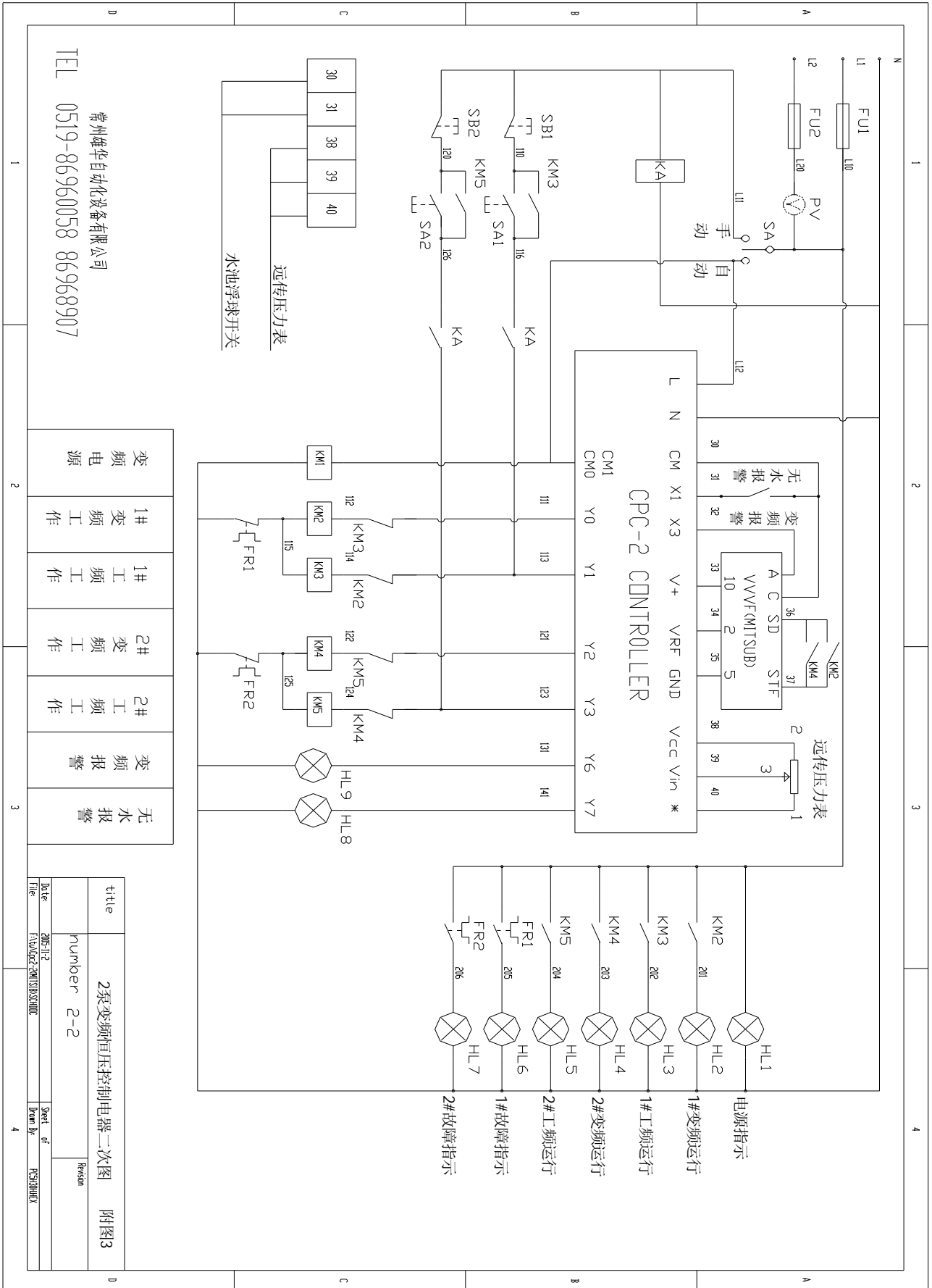

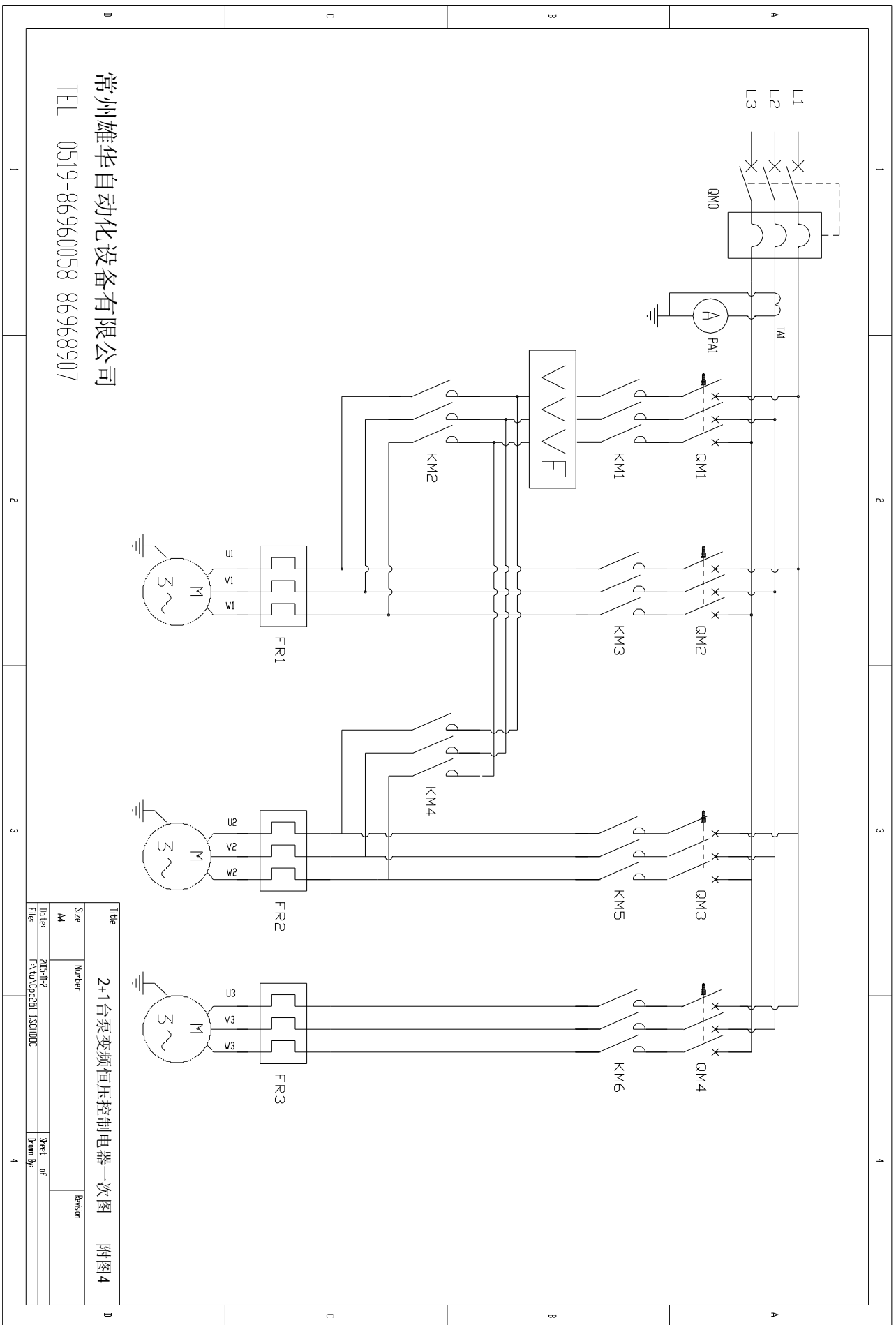

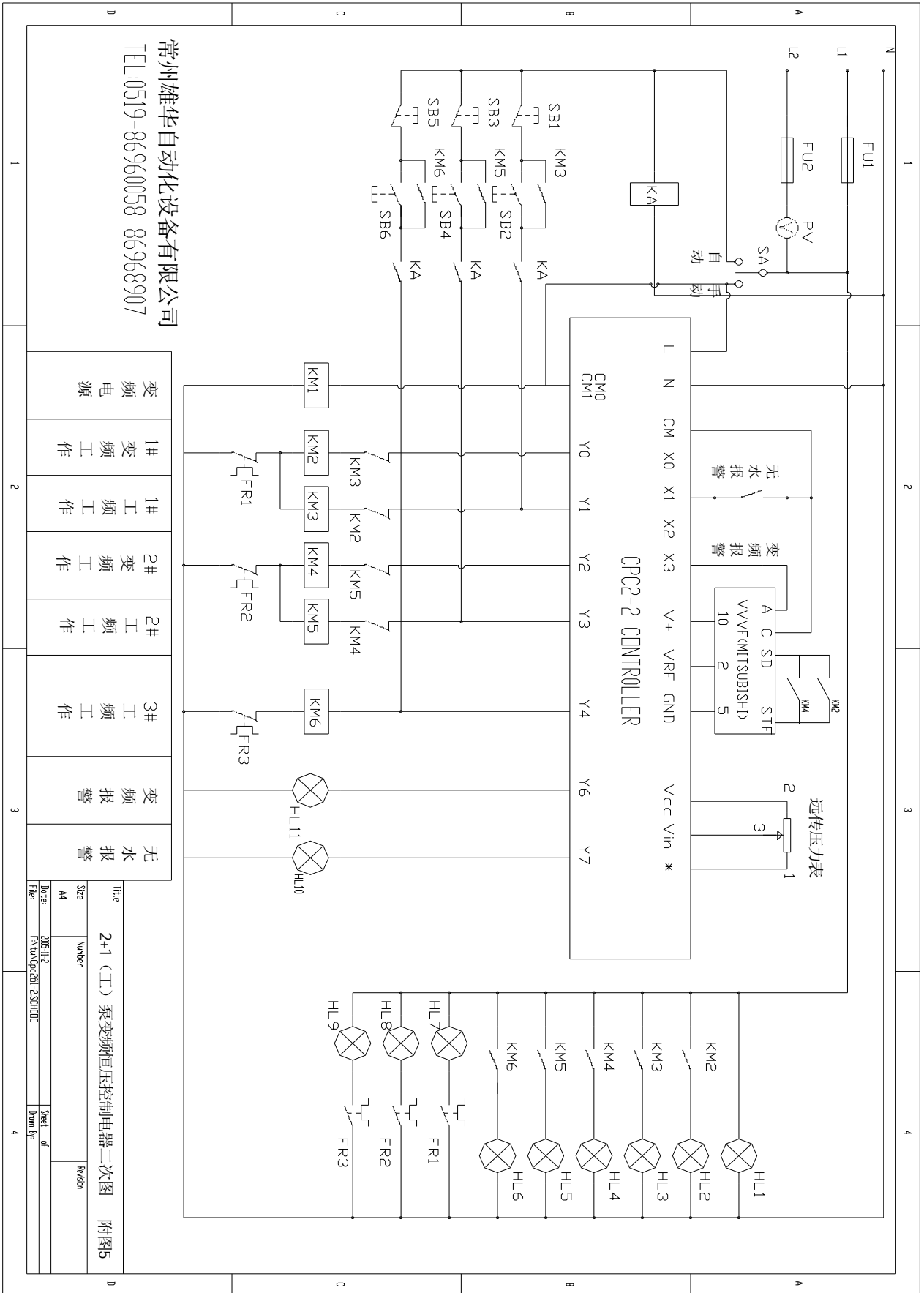

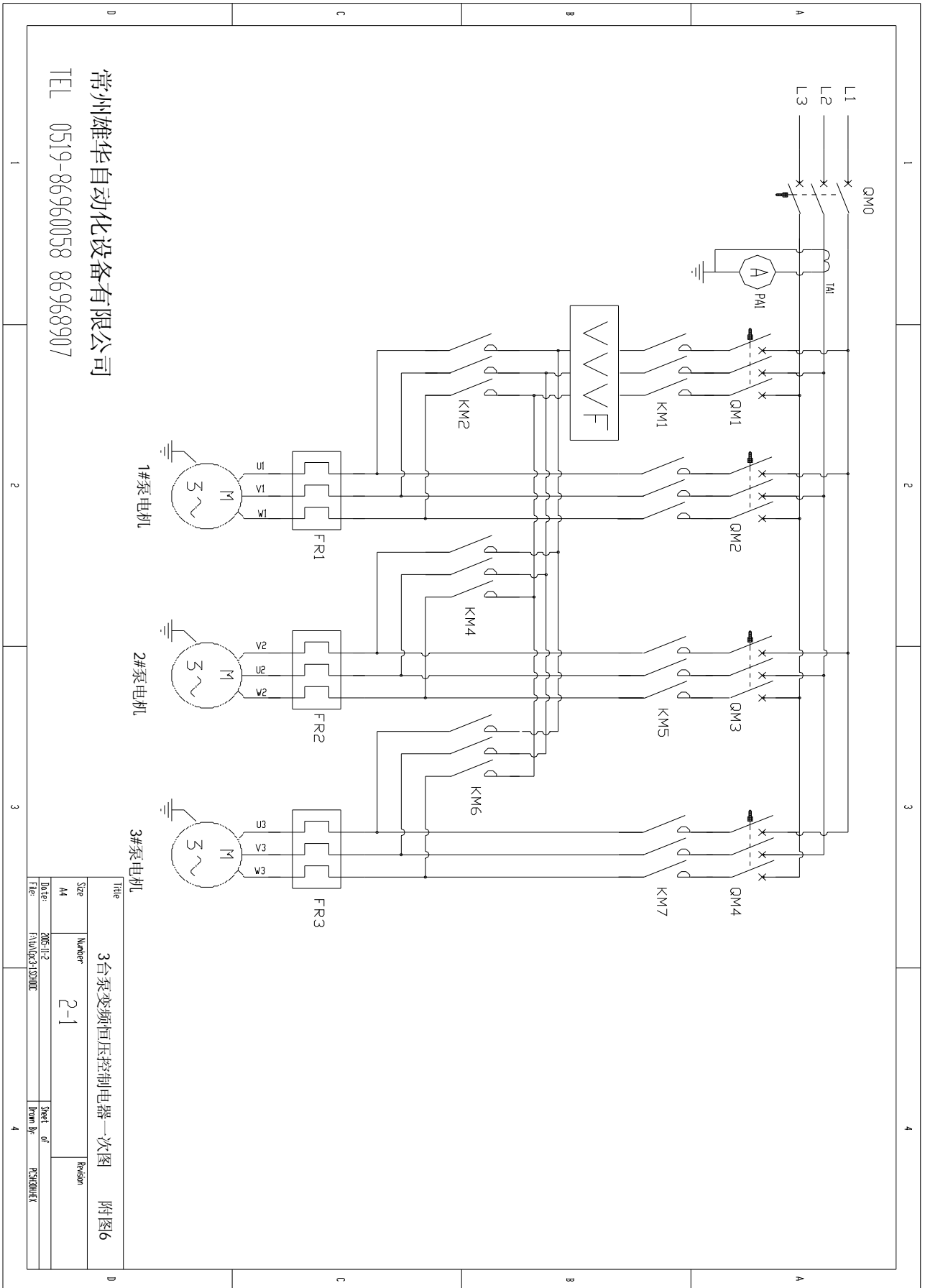

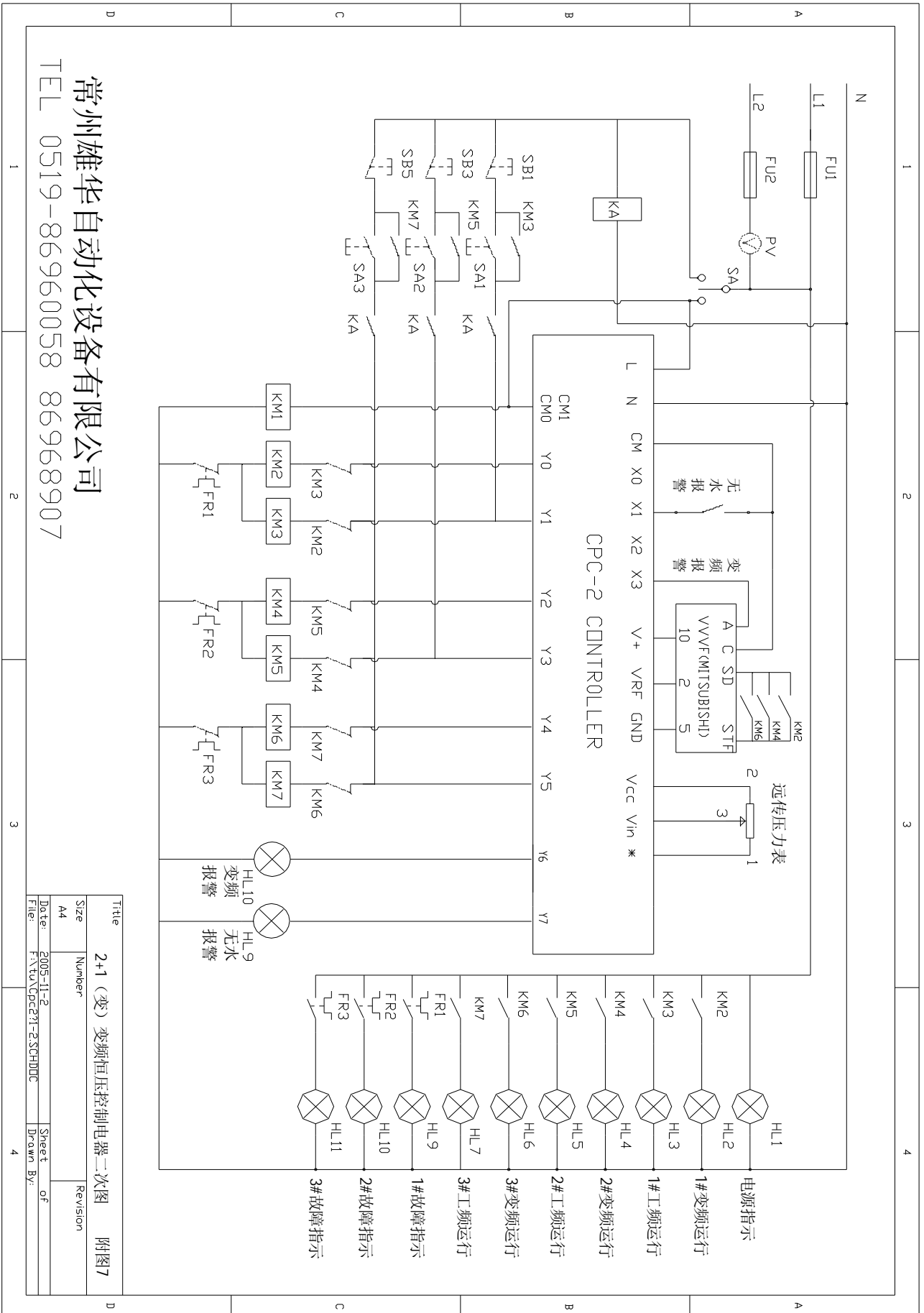

常州雄华自动化设备有限公司
TEL 0519-86960058 86968907

Title		2+1 (变) 变频恒压控制电器二次图 附图7	
Size	Number	Revision	
A4	2005-11-2		
Date:	F:\tvtu\Cpc2+1-2\SCHDOC	Sheet	of
File:		Drawn By:	

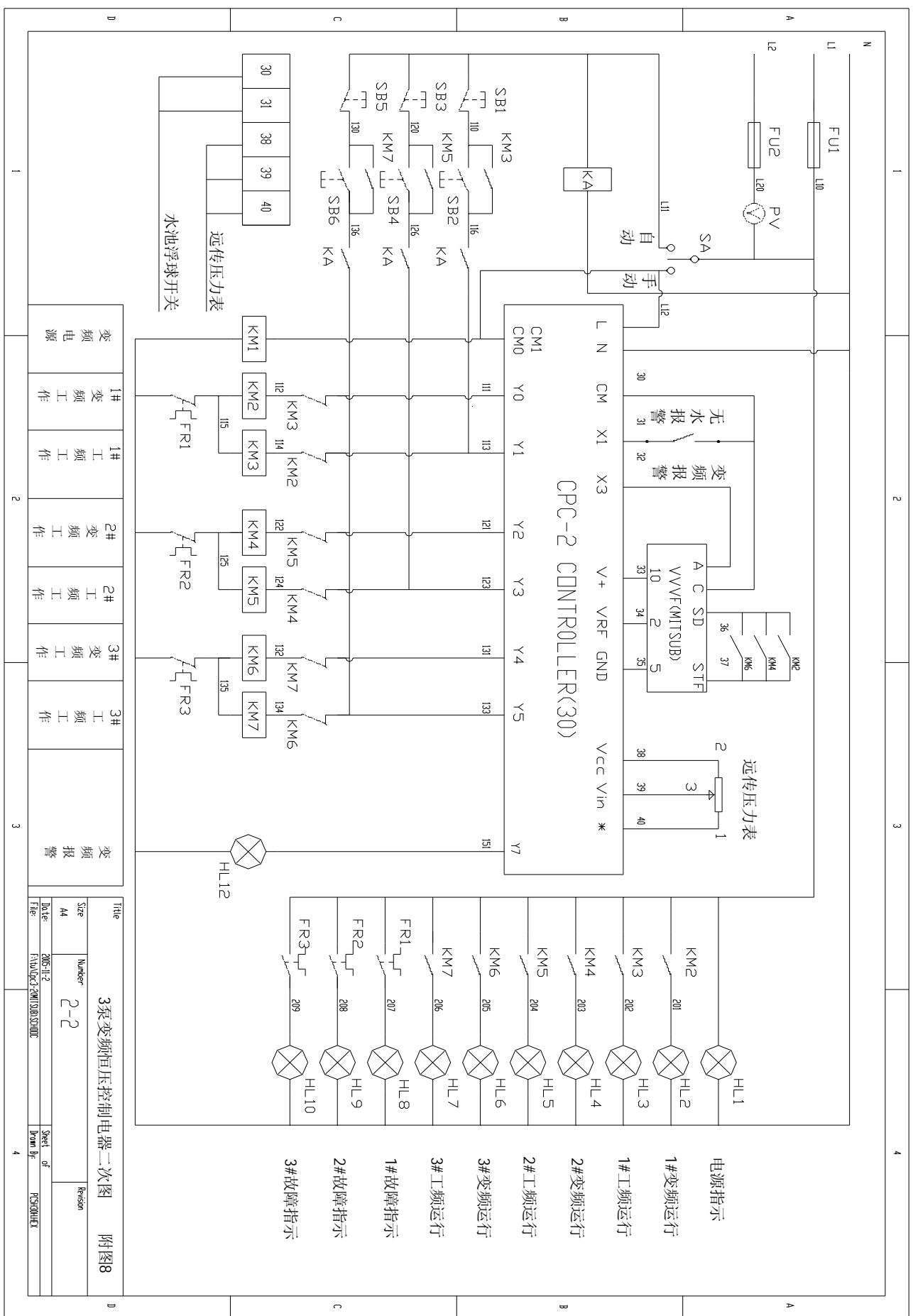

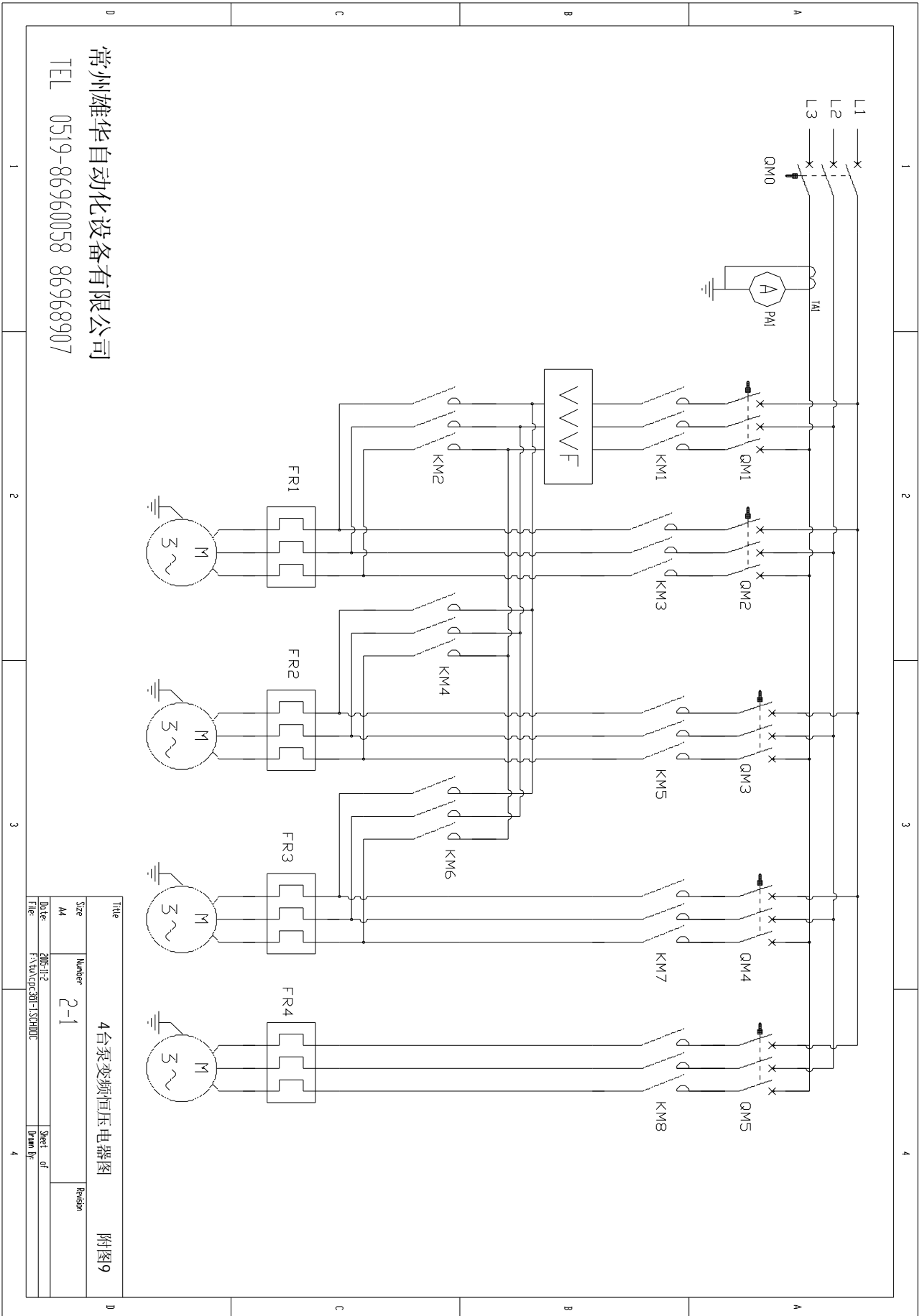

常州雄华自动化设备有限公司
 TEL 0519-86960058 86968907

Title		4台泵变频恒压电器图		附图9	
Size	Number	2-1		Revision	
A4					
Date	2006-11-2		Sheet of		Drawn by
File	F:\VAV\GDC\3B1-1\3B10DC		4		

