

Parameters:

- ◆720P Resolution
- ◆4MM Fixed Lens(Standard Configuration);
4MM,6MM,8MM,12MM Lens (Optional)
- ◆H.264 Video Compression
- ◆Progressive Scan CMOS
- ◆ICR Filter Auto Switch
- ◆66 Xφ5pcs LED,50-60M IR Distance
- ◆Free Client Software (UC2) , Free SDK

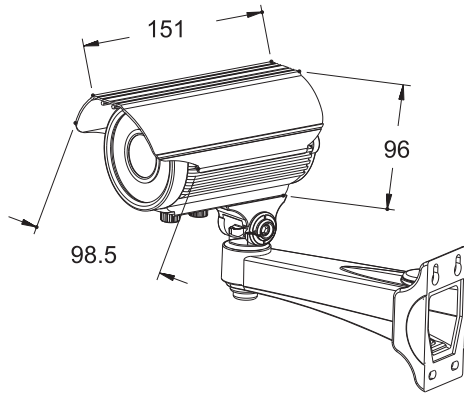

Model Number	AX-100WA-IP
Image Sensor	1/4"CMOS,720P, 1.0 Megapixel
System Structure	Embedded RTOS Design, Dual Core 32 Bit DSP(T1 DM365),Hard Compression, Watch Dog,32M FLASH,128M DDR2
Frame Rate	25fps(1280*720) ,1~25fps/s(Adjustable)
Image Output	Main Code Stream: 1280×720(Recording Resolution); Sub Code Stream: 640×360,480×270,320×180
Network Port	RJ45, 10/100M
Minimum Illumination	0Lux (IR On)
Electronic Shutter Speed	1/25s~1/20,000s
Lens	4MM Fixed Lens(Standard Configuration);4MM,6MM,8MM,12MM Lens (Optional)
Video Output	1Vp-p Composite Output (75 Ohm, BNC)
Video	H.264 Compression, Dual Streaming, AVI Format; streaming :0.1M~6Mpbs(Adjustable);Frame Rate:1~25fps/s(Adjustable);
Anti-flicker	Support
Motion Detection	Support
Password Protection	Support
Protocols	RTSP/FTP/PPPOE/DHCP/DDNS/NTP/UPnP
Power Supply	DC12V
Working Temperature	-10°C~60°C (14°F~140°F)
Dimensions	L151*W96 (MM)
Net weight	1.25KG
Color	Dark Gray

Specifications are subject to change without notice.