

WL-D-880  
WHEELCHAIR LIFT

XINDER-TECH ELECTRONICS



WL-D SERIES





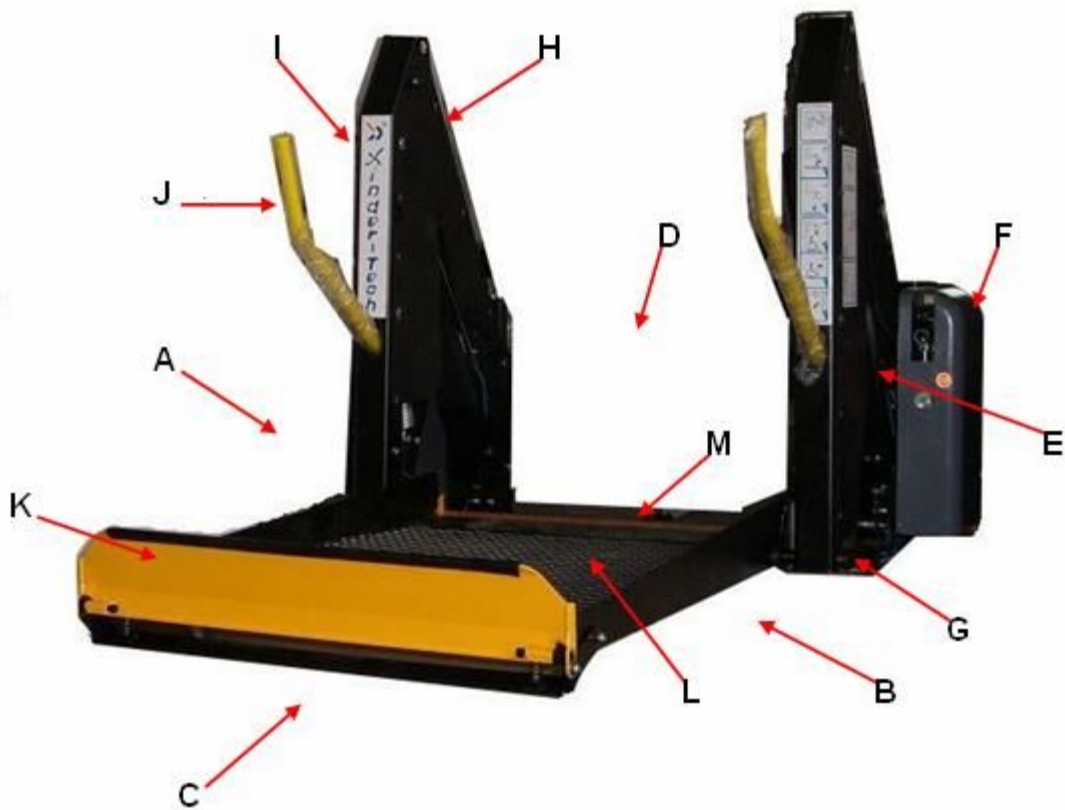

NO.	TERM
A	LEFT
B	RIGHT
C	FRONT
D	REAR
E	HYDRAULIC CYLINDER (LEFT&RIGHT)
F	HYDRAULIC POWER UNIT
G	BASEPLATE ASSEMBLY
H	TOP AND BOTTOM AREMS (LEFT&RIGHT)
I	VERTICAL ARMS (LEFT&RIGHT)
J	HANDRAILS (LEFT&RIGHT)
K	FRONT ROLLSTOP
L	PLATFORM
M	REAR ROLLSTOP
N	CONTROL PEDAL
O	MANUAL BACKUP PUMP HANDLE

This automatic wheelchair lift offers dependable accessibility while its trim, compact design maximizes valuable interior space. The lift also features a strong durable steel frame built to give you years of dependable service.

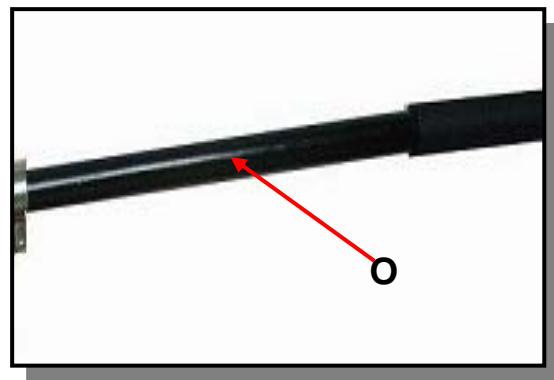

# LIFT TECHNICAL SPECIFICATIONS

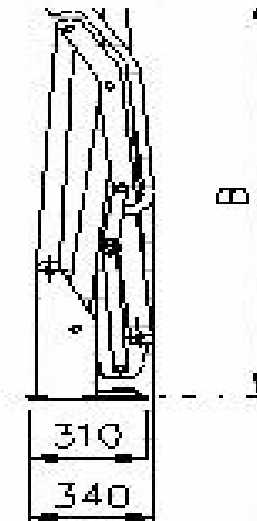
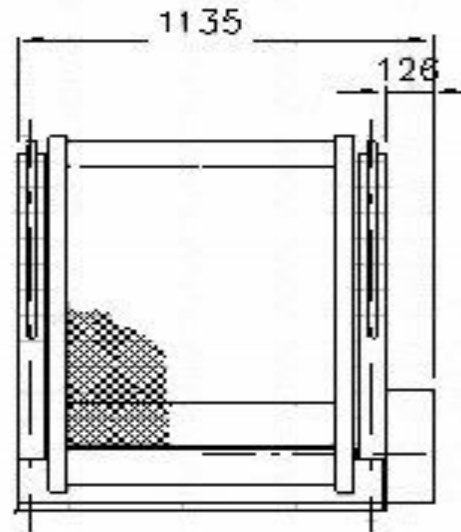
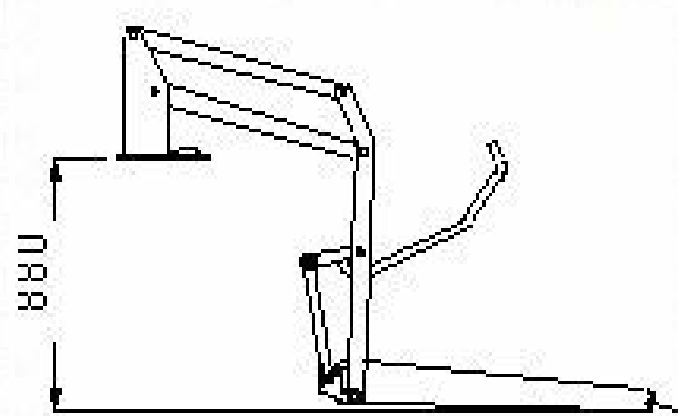
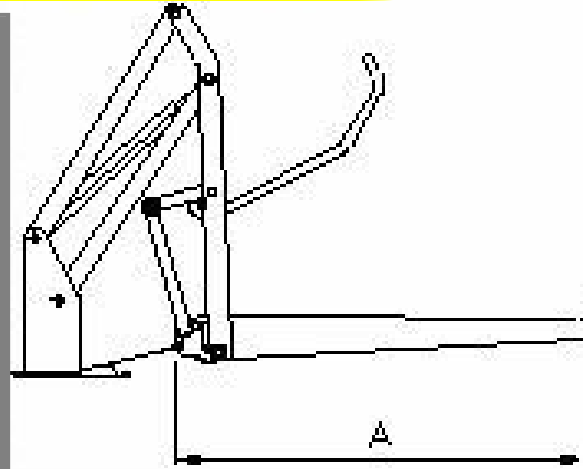

	A	B
1	1150mm	1220mm
2	1250mm	1320mm

<b>Lifting capacity: 320 kg</b>	<b>Lift weight: 145 kg</b>
<b>Electric system: 12V DC or 24V DC</b>	<b>Max working pressure: 14 Map</b>
<b>Max lifting height: 880 mm</b>	<b>Construction: Steel structure</b>
<b>Operation: Hydraulic pump with two lifting cylinder</b>	<b>Auxiliary emergency backup hand pump</b>



## LIFT FEATURES

- ◆ Automatic inboard and outboard rollstops
- ◆ Quiet and smooth operation
- ◆ Welded all-steel frame
- ◆ Built-in manual backup system
- ◆ Permanent no-lube bearings at all major pivot points, easy to maintain
- ◆ Side or rear door application
- ◆ Dual handrails for security and convenience
- ◆ Bridging feature prevents the wheelchair user from rolling off platform



CHANGZHOU XINDE-TECH ELECTRONICS CO., LTD

Add: 3<sup>rd</sup> Floor Jianshe B Building, Hanjiang rd., High&New Technology

Developing Zone, Changzhou, Jiangsu, China.

Tel: +86-519-85122329/85139690 Fax: +86-519-88226095

Web: [www.xinder.cn](http://www.xinder.cn)

E-mail: [master@xinder.cn](mailto:master@xinder.cn) [cgr@xinder.cn](mailto:cgr@xinder.cn)