

# Ball Valve

WB-02TE

2-PC Stainless Steel Ball Valve  
Full Port, 1000WOG, PN64, Economic Type

## FEATURES:

- Blow-out Proof Stem
- Investment Casting Body
- Pressure Balance Hole in Ball Slot
- Full Port
- Various Thread Standard Available
- Locking Device Available, **New Design**

## STANDARD:

- Design: ASME B16.34, API608
- Wall Thickness: 100% ASME B16.34, GB12224
- Face to Face: DIN3202-M3
- Pipe Thread: ANSI B 1.20.1, BS 21/2779, DIN 259/2999, ISO 228
- Inspection & Testing: API 598

NO.	PARTS NAME	MATERIAL		
		CF8M	CF8	WCB
1	Body	CF8M	CF8	WCB
2	Ball	CF8M	CF8	
3	Ball Seat	PTFE		
4	Stem	SS316	SS304	
5	Cap	CF8M	CF8	WCB
6	Cap Seal	PTFE		
7	Thrust Washer	PTFE		
8	Stem packing	PTFE		
9	Gland Nut	SS301		
10	Handle	SS301		
11	Spring Washer	SS301		
12	Stem Nut	SS304		
13	Locking Device	SS301		
14	Handle Cover	Plastic		

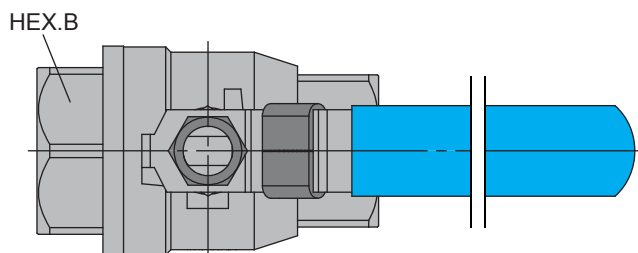
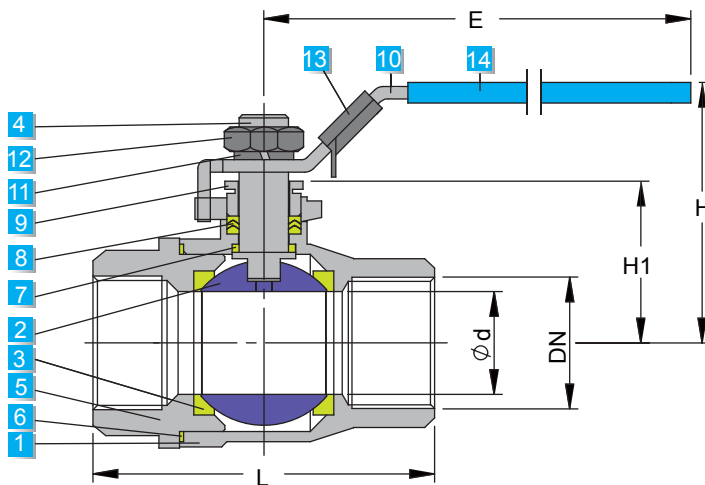

Unit:mm

DN	L	Ød	H	H1	E	HEX.B	END
1/4"	50	10.5	45	20.5	125	19	BSP BSPT PT DIN NPT etc...
3/8"	60	12.5	50	25	125	22	
1/2"	75	15	50	28	130	27	
3/4"	80	20	60	30.5	130	32	
1"	90	25	65	39	140	40	
1-1/4"	110	32	75	44	150	50	
1-1/2"	120	38	80	54	150	55	
2"	140	48	90	63	155	68.5	
2-1/2"	185	65	105	80	165	85	
3"	205	78	120	91	190	98	