

Ball Valve

WB-02T2

2-PC Stainless Steel Ball Valve
Full Port, 2000WOG, PN125

FEATURES:

- Blow-out Proof Stem
- Investment Casting Body
- Pressure Balance Hole in Ball Slot
- Full Port
- Various Thread Standard Available
- Locking Device Available, **New Design**

STANDARD:

- Design: ASME B16.34, API608
- Wall Thickness: 100% ASME B16.34, GB12224
- Face to Face: DIN3202-M3
- Pipe Thread: ANSI B 1.20.1, BS 21/2779, DIN 259/2999, ISO 228
- Inspection & Testing: API 598

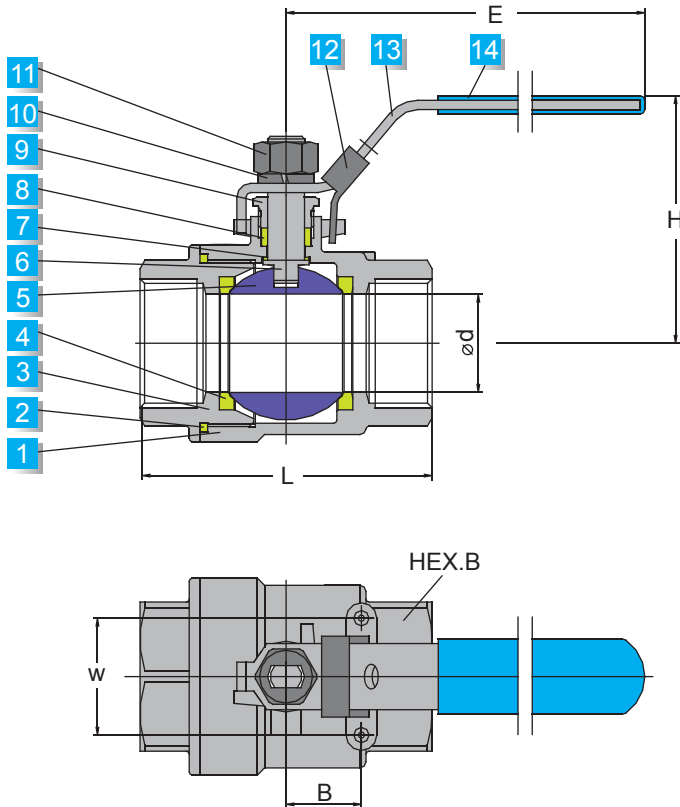

NO.	PART NAME	MATERIAL		
1	Body	CF8M	CF8	WCB
2	Body Gasket	PTFE		
3	Cap	CF8M	CF8	WCB
4	Ball Seat	PTFE	RPTFE	PEEK
5	Ball	CF8M	CF8	
6	Stem	SUS 316	SUS 304	
7	Thrust Washer	PTFE		
8	Stem Packing	PTFE	RPTFE	
9	Stop Nut	SUS 304		
10	Spring Washer	SUS 304		
11	Stem Nut	A193-B8		
12	Locking Device	SUS 301		
13	Handle	SUS 304		
14	Handle Cover	Plastic		



Size	L	ød	H	E	W	B	Thread
1/4"	58	10.5	53	90	28.5	12.7	NPT BSP PT DIN BSPT etc...
3/8"	58	12.5	53	90	28.5	12.7	
1/2"	62	15	53	100	28.5	12.7	
3/4"	72.5	20	60	125	34.8	22	
1"	85	25	75	140	34.8	22	
1-1/4"	94	32	80	140	38.1	23.6	
1-1/2"	105	38	90	185	38.1	23.6	
2"	125	50	100	185	38.1	23.6	
2-1/2"	155	65	125	240	65	35	
3"	175	80	130	240	65	35	