



SG-545244500 Series



(24VDC STANDARD)

DC GEARED MOTOR

OUTPUT POWER: 3.4W(APPROX)

WEIGHT:300~350g(APPROX)

Typical applications: Labal printers, auto shutter, automatic stabilized voltage supply, grill, oven, cleaning machine, garbage disposers, household appliances, slot machines, money detector, automatic actuator, coffee machine, towel disposal, lighting, coin refund devices, peristaltic pump.

MOTOR CHARACTERISTICS

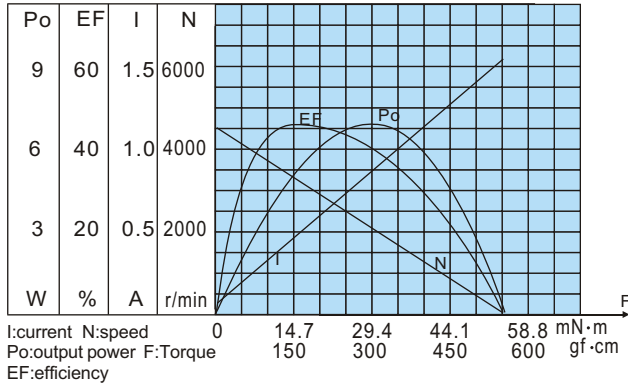

MOTOR TORQUE/SPEED/CURRENT

Rated voltage	24VDC
No load speed	4500r/min
No load current	110mA
Rated torque	130gf · cm 12.74mN · m
Rated current	0.50A
Rated speed	3350r/min
Stall torque	520gf · cm 50.96mN · m
Stall current	1.5A

APPEARANCE SIZE

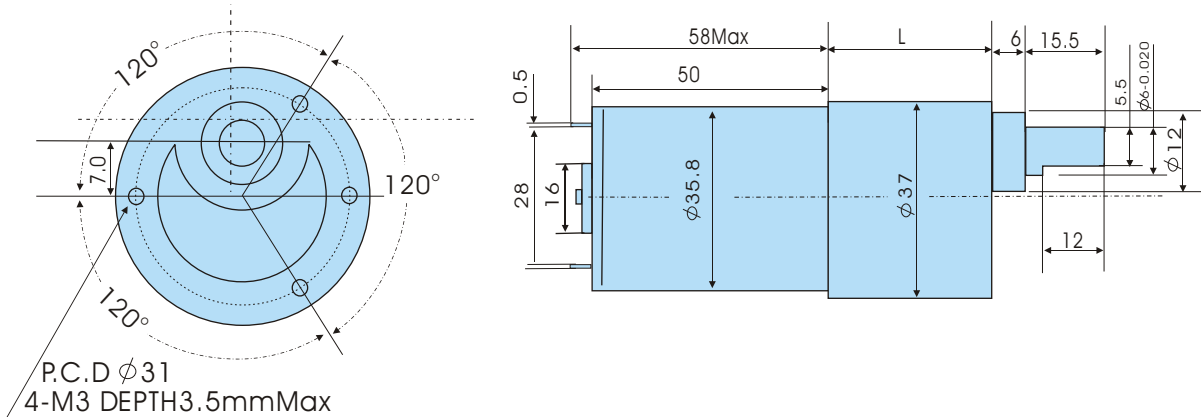

GEARED MOTOR TORQUE/SPEED/CURRENT

Geared motor name	Rated Volt. V	No load		Load torque				At maximum efficiency		Output power W	Number of gear trains	Gearbox length "L" mm
		Current mA	Speed r/min	Current mA	Speed r/min	Torque		Kgf · cm	N · m			
						Kgf · cm	N · m					
SG-545244500-10K	24	≤110	450	≤500	335	1.1	0.11	3	0.29	3.4	2	23
SG-545244500-20K	24	≤110	225	≤500	167	1.9	0.19	6	0.59	3.1	3	23
SG-545244500-30K	24	≤110	150	≤500	111	2.8	0.27	9	0.88	3.1	3	23
SG-545244500-60K	24	≤110	75	≤500	56	5.1	0.50	15	1.47	2.8	4	26
SG-545244500-90K	24	≤110	50	≤500	37	7.7	0.75	24	2.35	2.8	4	26
SG-545244500-180K	24	≤110	25	≤300	21	10	0.98	30	2.94	2.1	5	28
SG-545244500-270K	24	≤110	16.7	≤250	15	10	0.98	30	2.94	1.5	5	28
Packing Details	CTN size:28X26XH22.5CM 40pcs/CTN N.W. 14Kgs											