



Ningbo Realpower

Ltd.



Ningbo Realpower  
Magnetic Industry Co.,

LIFTING MAGNET  
SERIES



Lifting magnet tested to hold OVER THREE TIMES  
rated load for maximum safety  
for loads up to 2000kgs.  
Eliminates dangerous straps and slings  
Safe, efficient loading and unloading  
Request a handy application survey to help us determine  
the best model for your lifting needs

On all our lifting magnets there is a built-in safety factor  
of 3.0 times the rated load. This means that the safety  
factor is 3.0 times the maximum rated load for each

### Applications

Use the LM-B SERIES to move plate steel, block or  
round steel, and iron material in your shop. Super-  
powerful lifting magnet requires no electricity. It's  
perfect for loading or unloading most workpieces  
including press molds, plastic molds, machined parts,  
etc. Rated for up to 2000kgs!

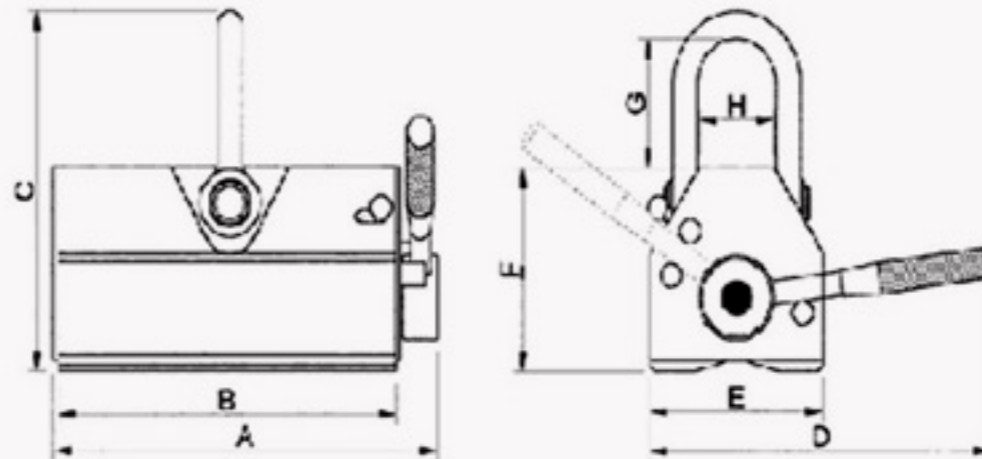

Maximum Rated Load Plate Steel			
Model	Material	Maximum Rated Load	Minimum Thickness
LM-150B	plate steel	150kg	20mm

LM-300B	plate steel	300kg	25mm
LM-600B	plate steel	600kg	30mm
LM-1000B	plate steel	1000 kg	45mm
LM-2000B	plate steel	2000kg	55mm

Maximum Rated Load Plate Steel				
Model	Material	Maximum Rated Load	Diameter Range	Minimum Length
LM-150B	round steel	80kg	50-200	20mm
LM-300B	round steel	150kg	25-300	25mm
LM-600B	round steel	300kg	100-500	30mm
LM-1000B	round steel	500kg	150-700	45mm
LM-2000B	round steel	1000kg	150-800	55mm

Dimensions(mm)									
Model	A	B	C	D	E	F	G	H	Wt.
LM-150B	105	85	120	125	60	70	40	30	3kg
LM-300B	180	155	155	185	90	95	50	40	9kg
LM-600B	250	225	210	260	115	120	75	50	23kg
LM-1000B	280	240	287	370	165	170	95	87	50kg
LM-2000B	420	380	350	500	215	215	105	125	120kg

LIFTING  
LM-B S



Powerful  
the rated  
Rated for  
Eliminate  
Fast, safe  
Use our  
the corre

**Note:**  
On all our  
of 3.0 times  
factor is  
magnet.

**WARNING: Never lift more than the maximum rated load.**

### Operation

Simply move the lever to the "ON" position to engage  
the magnet. Spring-loaded lock keeps the magnet  
engaged until you release it.