

SPECIFICATION OF LTCC FILTER LF43B1200H2111-N51

RoHS Compliant Parts

1. 概述 INTRODUCTION

微波带通滤波器 LF 系列产品设计用于 WLAN、GSM、Bluetooth、PDA 和无绳电话机中，具有低的插入损耗、高的衰减和小体积 SMD 片式设计，能减少复杂的调校工作，可以简化电路设计。Microwave Band-Pass filter LF series are designed to be used in WLAN、GSM、Bluetooth、PDA & cordless phones with low insertion loss and high attenuation as well as small size SMD chip design , which can simplify your complex tuning and circuit design .

2. 外型尺寸 Dimensions (Unit: mm)

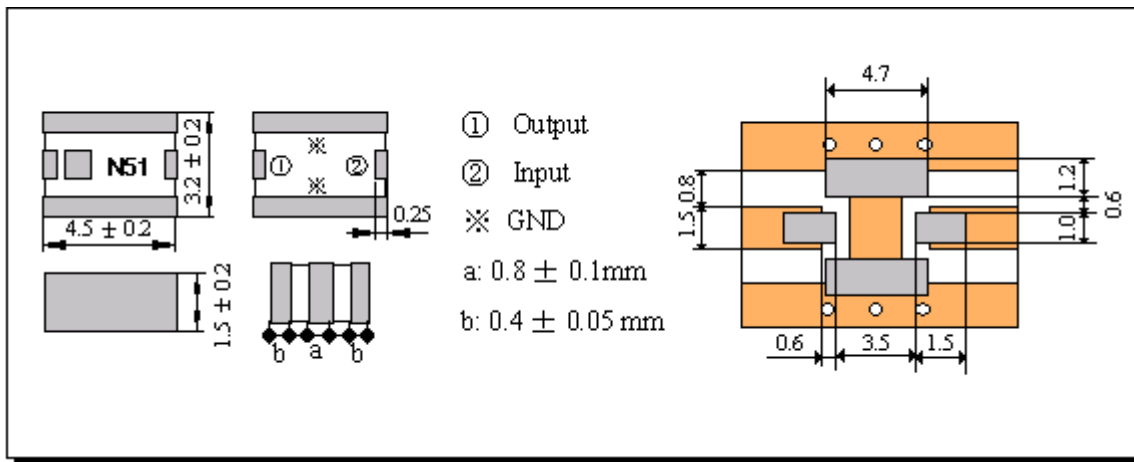

3. 结构及材料 Structure and Material

No	Part Name 名称	Structure and Material 结构及材料
3.1	Resonator 谐振体	Dielectric Material LTCC 介质材料
3.2	In/Output Terminals 输入/输出	Ag 银
3.3	Ground Base 接地面	Ag 银

4. 电气性能 Electrical Characteristics

No.	Item (项目)	Specifications (特性)
4.1	Center Frequency 中心频率 f_0	1200.0 MHz
4.2	Insertion Loss 插入衰减	≤ 2.0 dB (at $25^\circ\text{C} \pm 5^\circ\text{C}$)
		≤ 2.5 dB (at $-40^\circ\text{C} \sim 120^\circ\text{C}$)
4.3	Band Width 通带宽度	$f_0 \pm 250$ MHz
4.4	Ripple (in BW) 通带波动	≤ 1.0 dB
		≤ 0.3 dB (950.0~975.0 MHz) ≤ 0.3 dB (1425.0~1450.0 MHz)
4.5	V.S.W.R (in BW) 驻波比	≤ 1.8
4.6	Attenuation 阻带衰减	≥ 25 dB (450.0~806.0 MHz)
		≥ 21 dB (1650.0~2150.0 MHz)
4.7	Permissible Input Power 输入功率 (MAX)	1000 MW
4.8	In/Output Impedance 输入/输出阻抗	50 Ω

5.特性曲线 Characteristic curve



6. 环境试验后允许误差 Post Environmental Tolerance

经环境试验后允许比起始读数偏差见下表 Post Environmental Tolerance (Refer to the table)

No.	Item (项目)	Post Environmental Tolerance (环境试验后允许附加误差)
6.1	Center Frequency 中心频率 fo	±2.0 MHz
6.2	Insertion Loss 插入衰耗	±0.5 dB
6.3	Band Width 通带宽度	±1.0 MHz
6.4	Ripple (in BW) 通带波动	±0.5 dB
6.5	V.S.W.R (in BW) 驻波比	±0.2
6.6	Attenuation 阻带衰耗	±2.0 dB

7.环境试验 Environmental Test

基准条件: 温度范围	Temperature range	25 ± 5 °C
相对湿度范围	Relative Humidity range	55~75%RH
工作温度	Operating Temperature range	-40 °C ~+120 °C
贮藏温度	Storage Temperature range	-40 °C ~+120 °C

7.1 耐振动 Vibration Resist

在振动频率为 10~55Hz 振幅为 1.5mm 沿 X.Y.Z 方向各振动 2 小时后测试符合表 7.1~7.6 规定。

The device should satisfy the electrical characteristics specified in paragraph 7.1~7.6 after applied to the vibration of 10 to 55Hz with amplitude of 1.5mm for 2 hours each in X, Y and Z directions.

7.2 耐跌落冲击 Drop Shock

在 100cm 高度处按 X, Y, Z 三个面分别自由跌落在木制地板上共 3 次后测试符合表 7.1~7.6 规定。

The device should satisfy the electrical characteristics specified in paragraph 7.1~7.6 after dropping onto the hard wooden board from the height of 100cm for 3 times each facet of the 3 dimensions of the device.

7.3 耐焊接热 Solder Heat Proof

能承受经 120~150℃ 的温度预热 120 秒后, 在 230℃+10℃ 的焊锡浸 5 ± 0.5 秒。

The device should be satisfied after preheating at 120℃~150℃ for 120 seconds and dipping in soldering Sn at 230℃+5℃ for 5 ± 0.5 seconds.

7.4 结合力试验 Tensile Strength of Terminal

在产品电极端子上或表面上应能承受 1kg 垂直拉力 10 ± 1 秒。

The device should not be broken after tensile force of 1.0kg is slowly applied to pull a lead pin of the fixed device in the lead axis direction for 10 ± 1 seconds.

7.5 耐弯曲试验 Bending Resist Test

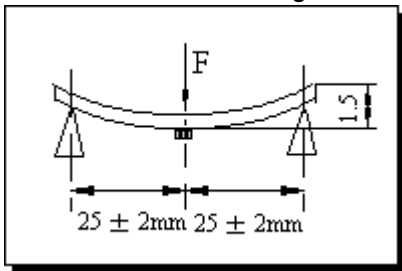

将产品按图焊在 1.6 ± 0.2mm 的 PCB 板中间, 由箭头方向施力: 1mm/S, 弯曲距离: 1.5mm, 保持 5 ± 1S, 产品金属层无脱落。

Weld the product to the center part of the PCB with the thickness 1.6 ± 0.2mm as the illustration shows, and keep exerting force arrow-ward on it at speed of 1mm/S, and hold for 5 ± 1S at the position of 1.5mm bending distance, so far, any peeling off of the product metal coating should not be detected.

7.6 耐湿热特性 Moisture Proof

在温度为 60 ± 2℃, 相对湿度 90~95% 的恒温湿箱中放置 96 小时, 在常温中恢复 1~2 小时后测试, 符合表 6.1~6.6 规定。

The device should satisfy the electrical characteristics specified in paragraph 6.1~6.6 after exposed to the temperature 60 ± 2℃ and the relative humidity 90~95% RH for 96 hours and 1~2 hours recovery time under normal condition.

7.7 高温特性 High Temperature Endurance

在温度为 120 ± 5℃ 的恒温箱中放置 24 ± 2 小时, 在常温中恢复 1~2 小时后测试。符合表 7.1~7.6 规定。

The device should satisfy the electrical characteristics specified in paragraph 7.1~7.6 after exposed to temperature 85 ± 5℃ for 24 ± 2 hours and 1~2 hours recovery time under normal temperature.

7.8 低温特性 Low Temperature Endurance

在温度为 -40℃ ± 5℃ 低温箱中放置 24 ± 2 小时后恢复 1~2 小时测试符合表 7.1~7.6 规定。

The device should also satisfy the electrical characteristics specified in paragraph 7.1~7.6 after exposed to the temperature -40℃ ± 5℃ for 24 ± 2 hours and to 2 hours recovery time under normal temperature.

7.9 温度循环 Temperature Cycle Test

在 -40℃ 温度中保持 30 分钟, 再在 +120℃ 温度中保持 30 分钟, 共循环 5 次后在常温中恢复 1~2 小时后测试符合表 7.1~7.6 规定。

The device should also satisfy the electrical characteristics specified in paragraph 7.1~7.6 after exposed to the low temperature -40℃ and high temperature +120℃ for 30 ± 2 min each by 5 cycles and 1 to 2 hours recovery time under normal temperature.

8 回流焊温度 Reflow Soldering Standard Condition

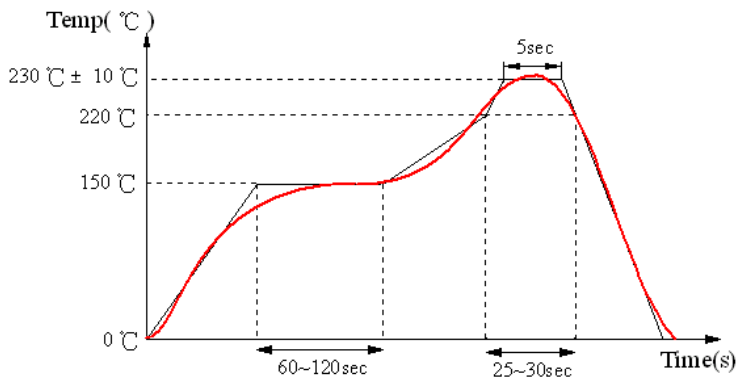

9.包装尺寸(4532) Packaging and Dimensions

9.1 Plastic Tape

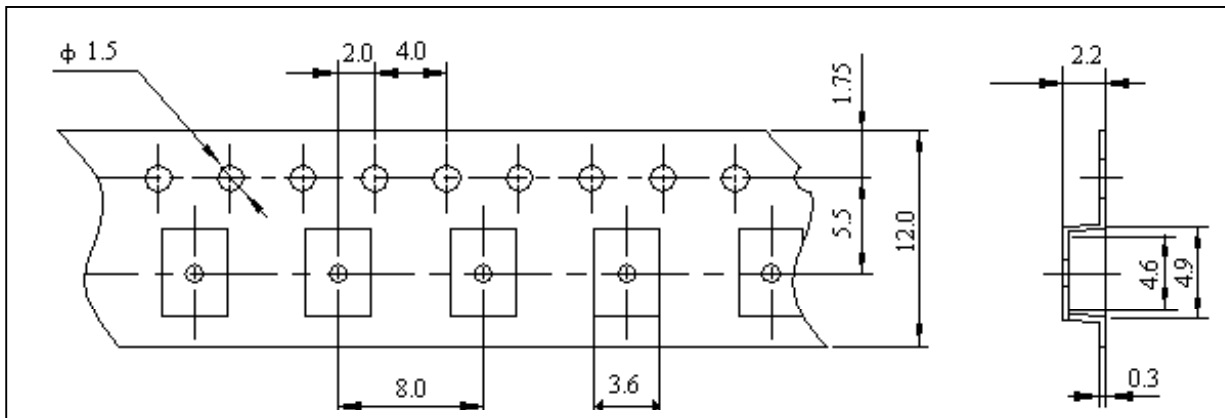

载带尾部空穴长度 150~200mm，载带头部空穴长度 250~300mm，头部的盖带加长 250mm。

Reserve a length of 150~200mm for the trailer of the carrier and 250~300 mm for the leader of the carrier and further 250mm of cover tape at the leading part of the carrier.

9.2 Reel (1000 pcs/Reel)

